



**Synergy of Meropenem and Ciproxin against Clinical Isolates of *Acinetobacter baumannii* and Detection of Antibiotic Resistant Genes for Quinolones and Carbapenems**

التعاون بين السيبروكسين والميروبينييم ضد الاسينيتوباكتر بوماني المعزولة سريريا في التجربة المخبرية  
وتحديد الانماط الجينية المقاومة للكوينولونز والكاربابينيمز

By

**Suzan Khamis Idkeidek**

Advisor

**Dr. Mohammad A. Farraj**

**This thesis was submitted in partial fulfillment of the requirements for the Master's Degree  
in Clinical Laboratory science from the faculty of Graduate Studies at Birzeit University  
Palestine**

**April, 2009**

*I dedicate this work to my beloved father  
**Khamis**, my mother **Sulafa**, my dear son  
**Hani**, , my sister **Sawsan** and my  
brothers **Ala'** and **Emad** who showed me  
the way and gave me the power and reason  
to accomplish this work. I love you all.*

## **Acknowledgments**

I would like to acknowledge Dr. Tamer Essawi, the founder of the Master's Program in Clinical Laboratory Science who provided us with the opportunity to obtain graduate education in our country, Palestine. He was always supportive and encouraging. I would like to give my thanks and deep appreciation to my advisor, Dr. Mohammad Farraj, who taught me how to work independently and the meaning of hard work and provided me with the guidance I needed to finish my project. Dr. Hatem Eideh, was supportive and cooperative in several aspects of this research, I thank him. I would like to acknowledge the staff and administration of Al-Makassed Hospital. They were very generous in providing me with the time and samples I needed to conduct this important research. Special thanks and appreciation go to my co-workers and friends at Al Makassed Hospital, Mrs. Enas Abdel Latif, and Mr. Mohammad Tomaizi. I would like to thank Mr. Shadi Al-Rifa'e for providing me with the materials I needed throughout this project. Thanks to all my friends who encouraged me continuously to finish this work.

SKI

## Table of Contents

<u>Chapter</u>	<u>Description</u>	<u>Page</u>
	Description of Al-Makassed Charitable Hospital .....	1
1	Introduction.....	2
	- <i>Acinetobacter spp</i> .....	2
	- Infections caused by <i>Acinetobacter baumannii</i> .....	4
	- Risk Factors for Acquiring <i>A. baumannii</i> .....	6
	- Sources of <i>A. baumannii</i> transmission in hospitals .....	7
	- Epidemiology .....	8
	- Antimicrobial Susceptibility .....	9
	- Combination Therapy .....	11
	- Mechanisms of Resistance .....	13
	- Antibiotic Resistant Genes in Multidrug Resistant <i>A. baumannii</i> .....	15
	Carbapenems .....	15
	Fluroquinolones .....	17
	Aminoglycosides .....	19
	Cephalosporins .....	21
	Treatment .....	22
	Prevention .....	24
	Aims of The Study .....	27

<b><u>Chapter</u></b>	<b><u>Description</u></b>	<b><u>Page</u></b>
2	Materials and methods .....	28
	- Specimens collection .....	28
	- Antimicrobial Susceptibility Testing .....	29
	- PCR Amplification, DNA Sequencing, and Restriction Endonuclease Digestion .....	31
3	Results .....	34
	- Antimicrobial Susceptibility Testing .....	34
	- Synergy Testing .....	38
	- PCR amplification for carbapenemases .....	42
	- PCR amplification of QRDR of <i>ParC</i> and <i>gyrA</i> .....	46
4	Discussion .....	50
	Recommendations .....	56
	References .....	57

## List of Tables

<b><u>Table</u></b>	<b>Description</b>	<b><u>Page</u></b>
1.	Checkerboard used to test combination of meropenem and ciproxin. Rows: meropenem, Columns: Ciproxin.....	31
2.	Primers and annealing temperatures used for the amplification of genes in <i>A. baumannii</i> isolates-----	33
3.	<i>A. baumannii</i> (n=85) MIC ranges and distributions for ciproxin by agar dilution. (S: sensitive, I: intermediate, R: resistant)----- -----	35
4.	<i>A. baumannii</i> (n=85) MIC ranges and distributions for ciproxin by agar dilution. (S: sensitive, I: intermediate, R: resistant)----- -----	36
5.	<i>A. baumannii</i> (n=85) MIC ranges and distributions for colistin sulfate by agar dilution. (S: sensitive, I: intermediate, R: resistant)-----	37
6.	<i>A. baumannii</i> isolates susceptibility to Meropenem. Ciproxin and Colistin sulfate (MIC50, MIC90, sensitive, intermediate and resistant percentages)-----	37
7.	Frequency (%) of outcome ( synergy, partial synergy, additive, indifference and antagonism)-----	40
8.	<i>A. baumannii</i> synergy testing results as a function of meropenem MIC-----	41
9.	<i>A. baumannii</i> synergy testing results as a function of ciproxin MIC-----	41
10.	Number of isolates detected carrying carbapenemases genes----- -----	42
11.	Number of mutated isolates ( uncut when digested with <i>HinfI</i> ) and nonmutated ones (cut into 2 fragments when digested with <i>HinfI</i> )-----	47

## List of Figures

<u>Figure</u>	<u>Description</u>	<u>Page</u>
1.	A: Morphological appearance of <i>A. baumannii</i> on blood agar plates. B: Gram staining of a colony taken from the agar plate-----	3
2.	Steer's Replicator-----	10
3.	Selection pressure for antimicrobial resistant strains-----	12
4.	Structure of carbapenem backbone-----	15
5.	Countries that have reported an outbreak of carbapenem-resistant <i>Acinetobacter baumannii</i> . Red signifies outbreaks reported before 2006, and yellow signifies outbreaks reported since 2006 (51)-----	17
6.	Structure of quinolone backbone-----	18
7.	Structure of aminoglycoside backbone-----	20
8.	Structure of Cephalosporine backbone-----	21
9.	Structure of Colistin backbone-----	23
10.	Structure of Tigecyclin backbone-----	24
11.	Distribution of <i>A. baumannii</i> isolates according to hospital wards at Makassed Charitable Hospital-----	29
12.	Representative sample for antimicrobial susceptibility by the agar dilution method using Steer's replicator-----	30
13.	Percent susceptibility of <i>A. baumannii</i> to ciproxin-----	35
14.	Percent susceptibility of <i>A. baumannii</i> to meropenem-----	36
15.	Antimicrobial susceptibility of <i>A. baumannii</i> to ciproxin, meropenem and colistin-----	38

16	Percentage of <i>A. baumannii</i> isolates demonstrating antimicrobial susceptibilities in combinations of ciproxin and meropenem-----	40
17	Class D expression in <i>A. baumannii</i> resistant to meropenem, 59 resistant and Intermediate isolates-----	43

<b><u>Figure</u></b>	<b><u>Description</u></b>	<b><u>Page</u></b>
----------------------	---------------------------	--------------------

18.	<i>Class D expression in A. baumannii</i> susceptible to meropenem, 26 isolates-----	43
19.	Representative gel showing the PCR products for the different oxacillinase genes. LaneM: 100-pbladder, Lane1: oxa-58, lane2: oxa 23, lane 3: oxa-51, lane 4: oxa24-----	44
20.	Representative gel showing the PCR products for Oxa-24. Lane M: 100-bp ladder, lanes 1,2, 4 and 5: resistant <i>A. baumannii</i> isolates to meropenem. Lane3: meropenem susceptible <i>A. baumannii</i> isolate (heteroresistant)-----	45
21.	Detection of heteroresistant <i>A. baumannii</i> for meropenem. Heteroresistant colonies are located inside the susceptibility zones of imipenem and meropenem-----	46
22.	Correlation of mutations in the <i>gyrA</i> and <i>parC</i> according to individual MICs obtained for <i>A. baumannii</i> isolates-----	47
23.	Representative gel for <i>parC</i> gene. Lane M: 100bp ladder. Lane1: undigested PCR product. Lane2: <i>A. baumannii</i> susceptible to ciproxin and digested with <i>HinfI</i> (Cut). Lane 3: <i>A. baumannii</i> resistant to ciproxin (MIC=16) and digested with <i>HinfI</i> (Cut). Lane4: <i>A. baumannii</i> resistant to ciproxin (MIC=32) and digested with <i>HinfI</i> (uncut). Lane5: <i>A. baumannii</i> resistant to ciproxin (MIC=128) and digested with <i>HinfI</i> (uncut)-----	48
24	Representative gel for <i>gyrA</i> products of <i>A. baumannii</i> . LaneM: 100 bp ladder. Lane1: undigested PCR product. Lanes 2, 3, 4, 5, 6 and 7: Digested PCR products by <i>HinfI</i> with MICs of 0.5, 4, 8, 32, 64 and 128 respectively. Lane 2: susceptible (Cut). Lane 3,4,5,6 and 7 resistant (uncut)-----	49



## List of Abbreviations

MDR	Multidrug Resistant
MIC	Minimum Inhibitory Concentration
MBC	Minimum bactericidal Concentration
FIC	Fractional Inhibitory Concentration
ICU	Intensive Care Unit
CLSI	Clinical Laboratory Standard Institute
FDA	Food and Drug Administration
MBL	Metallo Beta Lactamase
Oxa	Oxacillinase
ESBL	Extended Spectrum Beta Lactamase
QRDR	Quinolones Resistant Determining Region
PBP	Penicillin Binding Protein
AAC	Aminoglycoside Acetyltransferases
APH	Aminoglycoside Phosphotransferases
ANT	Aminoglycoside nucleotidyltransferases
ADC	<i>Acinetobacter</i> -Derived Cephalosporinases
PCR	Polymerase Chain Reaction
<i>bla</i>	Beta lactam
RFLP	Restriction Fragment Length Polymorphism

## Abstract

*Acinetobacter baumannii* has emerged as a major nosocomial pathogen. Meropenem and imipenem are the most commonly used antimicrobials to treat infections inflicted by this pathogen. Recently, resistance mechanisms have evolved causing this microorganism to become resistant to these antibiotics.

Eighty five clinical isolates of *A. baumannii* were collected from inpatients at Makassed Islamic Hospital in Jerusalem, Palestine. Antimicrobial susceptibility testing was performed against several antibiotics including meropenem, ciproxin and colistin. Minimal Inhibitory Concentration was performed on these three antibiotics individually and on meropenem and ciproxin in combination. Polymerase chain reaction was performed to detect mutations in the Quinolone Resistant Determining Region for selection *gyrA* and *parC* genes. In addition, PCR was performed to detect the acquisition of beta lactam class D oxacillinase genes, specifically *oxa24*, *oxa23*, *oxa51* and *oxa58*. Representative samples were sequenced to confirm the presence of mutations responsible for quinolone resistance and the presence of beta lactam oxacillinase genes responsible for carbamepenem-resistance.

The results obtained revealed that *A. baumannii* was resistant to ciproxin (86%), meropenem (74%) and none was resistant to colistin. Combination results revealed the existence of synergy between ciproxin and imipenem where the MICs were elevated in both (9.5%). Partial synergy was seen in situations when the organism was resistant to both drugs with the MIC elevated for one of the two drugs tested (52%).

Our results indicated the presence of correlation between resistance to ciproxin and mutations on *gyrA* at codon 83 for all isolates with MIC  $\geq 2$   $\mu\text{g/ml}$ . Sequencing revealed the presence of substitution of serine to leucine. Mutations in the *parC* gene were detected on codon 80 only when the MICs were  $\geq 32$   $\mu\text{g/ml}$ .

Among the *A. baumannii* resistant isolates to meropenem, our results revealed that all isolates carried *oxa51*, 86.7% carried *oxa24* while only 3.3% carried by each of *oxa23* and *oxa58* genes.

Regarding *gyrA* and *parC*, our results agree with published literature as in many other countries. Regarding beta lactamase genes, the rate of *oxa24* carriage seems to be similar to results obtained by other Mediterranean and European countries such Spain and Portugal. A small number of isolates carried the other clusters of beta lactamases pointing to the potential of further spread of these genes.

The aim of this project was to investigate the antimicrobial susceptibility pattern of *A. baumannii* and to determine the presence of synergistic effects between meropenem and ciproxin. In addition, we investigate the presence of mutations on the *gyrA* and *parC* genes, responsible for quinolone resistance, and the acquisition of beta lactamase genes *oxa51*, *oxa24*, *oxa23* and *oxa51* responsible for carbapenem resistance.

## الخلاصة

تعتبر بكتيريا الاسينيتوباكتر بوماني من أهم الجراثيم المسببة للأمراض المعدية في المستشفيات. أكثر المضادات الحيوية المستخدمة لعلاج العدوى الناتجة عن هذه البكتيريا هما ميروبيينيم و اميبينيم . ولقد نشأت طرق تسببت في مقاومة هذه البكتيريا للمضادات الحيوية.

لقد تم جمع 85 عينة من المرضى المقيمين في مستشفى المقاصد الخيرية الإسلامية في مدينة القدس في فلسطين. تم فحص يمنع (MIC) استجابة هذه الجراثيم لعدة مضادات حيوية منها ميروبيينيم، سيبروكسين وكوليستين. وكذلك تم تقدير أقل تركيز لتحديد PCR نمو هذه الجرثومة باستخدام المضادات الحيوية الأنفة الذكر فرادى وميروبيينيم والسيبروكسين معا. عمل فحص عمل PCR ، بالإضافة *gyrA and parC* الطفرات الوراثية الموجودة على منطقة تحديد المقاومة للكوينيلونز لجينات اختيرت بعض *Oxa24, oxa23, oxa51 and oxa58* اوكسيلينيز وتحديد D لتحديد اكتساب جين بيتا لاكتام من صنف للتأكد من وجود طفرات مسببة لمقاومة هذه البكتيريا للكوينيلونز واكتساب جينات بيتا لاكتام DNA العينات لتحديد سلسلة المذكورة المسؤولة عن المقاومة للكارباميبينيم .

أظهرت نتائج هذه الدراسة بأن 86% من هذه الجرثومة مقاومة للسيبروكسين، 74% للميروبيينيم وعدم وجود أي مقاومة مرتفع MIC للكوليستين. كما أظهرت النتائج وجود تعاون كلي بين الميروبيينيم والسيبروكسين في 9.5% في حالات وجود لأحدهما. MIC لكلا المضادين الحيويين وتعاون جزئي بنسبة 52% عند وجود مقاومة لكلا المضادين الحيويين مع ارتفاع على كودون 83 لجميع الجراثيم المعزولة *gyrA* كما تبين وجود علاقة بين المقاومة للسيبروكسين ووجود طفرة على جين تحديد مكونات السلسلة الامينية لهذا الجين، تبين وجود احلال للحامض الاميني سيرين للوسين. MIC  $\geq 2 \mu\text{g/ml}$  ولها MIC  $\geq 32 \mu\text{g/ml}$  فالطفرة كانت موجودة على الكودون 80 لجميع الجراثيم المعزولة ولها *parC* بالنسبة لجين ال

جين بنسبة 100%، جين *oxa51* من بين بكتيريا الاسينيتوباكتر بوماني المقاومة للميروبيينيم، أسفرت نتائجنا عن وجود *oxa23* و *oxa58* بنسبة 86.7% ونسبة 3.3% لكل من *oxa24*.

توافقت نتائجنا مع الدراسات العالمية. أما بالنسبة للنتائج لجينات البيتا لاكتاميز، فتبين ان هذه ، *parC* و *gyrA* بالنسبة ل تماثل نتائج الدراسات المعمولة في اسبانيا والبرتغال. وجود عدد قليل من *oxa24* النتائج للجين المسؤول عن المقاومة وهو الجراثيم المعزولة والتي تحمل جينات بيتا لاكتاميز اخرى يؤكد على احتمالية انتشارها في منطقتنا

الهدف من هذه الدراسة هو تحديد مدى مقاومة بكتيريا الاسينيتوباكتر بومانيي ووجود فعالية تعاون بين المضادين الحيويين المسؤولة عن مقاومة هذه الجرثومة للكويكيلونز واكتشاف *gyrA* و *parC* ميروبيينيم و سيبروكسين مع تحديد الطفرات لجينات المسؤولة عن عدم استجابة هذه *oxa58* و *oxa23* ، *oxa24* ، *oxa51* احتمال اكتساب احد جينات البيتا لاكتاميز مثل الجرثومة للكاربامبيينمز.

## **Description of Makassed Islamic Charitable Hospital**

Makassed Islamic Charitable Society was officially established in 1956. It is a Palestinian non-profit, non-governmental organization that provides diversified human services and extends its services in accordance with its laws, without discrimination of religion, gender, color, creed, or political affiliations. In 1964, the society built its hospital on the Mount of Olives in Jerusalem. The hospital was officially inaugurated in 1968 as a small community hospital with few departments and a limited number of beds.

Makassed hospital now is a leading medical center in Palestine providing secondary and tertiary health for the population; it provides services to patients from all over Palestine. Makassed Hospital has the capacity of 250 beds, staffed by 560 employees.

Makassed hospital consists of 10 main departments: Surgical department (general and Laparoscopic Surgery, Neurosurgery, Vascular, Thoracic, Open Heart, Plastic, Maxillofacial, Orthopedics, Urology, and Pediatric Surgery), Internal Medicine and Cardiology, Pediatric department, Gynecology department, Anesthesia department, Neonatal department, Emergency department, Genetics department and Radiology department. It also consists of supportive services in Outpatient clinics, central Blood Bank, and General Hospital Laboratory (provides variety of routine and specialized tests with strict internal and external quality control measures).

Makassed Hospital has its own nursing School, and has a residency program in many specialties, and it is active in both clinical and basic sciences research.

The annual number of admissions ranges between 10000 to 11000, the outpatient visits between 34000 to 37000, the Emergency visits between 15000 to 17000, the surgical operations between 3500 to 4500.

## Introduction

### *Acinetobacter Spp.:*

The current genus designation, *Acinetobacter* (Greek, akinetos, or nonmotile), was initially proposed by Brisou and Pre´vot in 1954 to separate the nonmotile microorganisms from the motile ones within the genus *Achromobacter* (1). It was not until 1968 that this genus designation became widely accepted (2). The genus *Acinetobacter*, as currently defined, comprises Gram-negative, strictly aerobic, nonfermenting, nonfastidious, nonmotile, catalase-positive, oxidase-negative bacteria with a DNA G+C content of 39% to 47%. Based on more recent taxonomic data, it was proposed that members of the genus *Acinetobacter* should be classified in the new family Moraxellaceae within the order Gammaproteobacteria, which includes the genera *Moraxella*, *Acinetobacter*, *Psychrobacter*, and related organisms (3).

The genus *Acinetobacter* is commonly found in soil and water, it can also be found on the skin of healthy people especially healthcare workers. All types or species of *Acinetobacter* can cause human disease, mainly *A. baumannii* which accounts for about 80% of reported infections. This genus consists of at least 12 DNA hybridization groups referred to as genospecies. The individual genospecies are classified as follows:

Genospecies 1, the type species for *A. calcoaceticus* which isolated principally from soil.

Genospecies 2, for *A. baumannii* which includes all isolates previously referred to as *A. calcoaceticus* var. *anitratius*, it is the most prevalent species isolated from human clinical specimens.

Genospecies 4 is named *A. haemolyticus*.

Genospecies 5 is named *A. jinii*.

Genospecies 7 is named *A. johnsonii*.

Genospecies 8 is named *A. lwoffii*.

Genospecies 3, 6, 9, 10, 11, and 12 are unnamed.(4 , 5)

*Acinetobacter* cells are short, gram-negative rods, measuring 1-1.5 by 1.5-2.5 microns during growth; they often become more coccoid during stationary phase. Cells are pleomorphic aerobic found in pairs or small clusters of coccobacilli by Gram's staining similar to *H. influenzae* as shown in Figure 1B. The organism has a tendency to retain crystal violet leading to incorrect identification as gram-positive cocci particularly in older cultures. Most strains grow well on nonselective agar forming smooth pale colonies as shown in Figure 1A. On MacConkey agar, the colonies are faint with blue tint while forming deeper cornflower blue color on eosin methylene blue agar (5).



Figure 1A.

A. Morphological appearance of *A. baumannii* on blood agar plates.

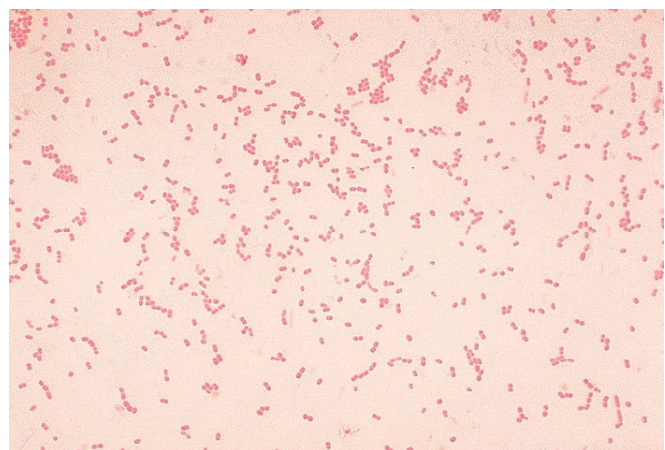

Figure 1B

B. Gram staining of a colony taken from the agar plate (4).



*Acinetobacter* are non fermenters utilizing a wide variety of carbon and other energy sources. The organism can survive for months on clothing and bed sheets, bed rails, ventilators and other surfaces including sinks and doorknobs, making nosocomial transmission extremely difficult to control.

*A. baumannii* does not have fastidious growth requirements. It grows at various temperatures and pH levels. This versatile organism exploits a variety of both carbon and energy sources. These properties explain the ability of *Acinetobacter* species to persist in either moist or dry conditions in the hospital environment, thereby contributing to its transmission and spread. This hardiness combined with its intrinsic resistance to many antimicrobial agents, contribute to the organism's fitness and ability to spread in the hospital setting (6).

Features present on the outer cell membrane in gram negative bacteria such as porins and efflux channels contribute to antibiotic resistance. Porins are protein channels that allow the transport of molecules across the outer cell membrane and serve as attachment sites for antibiotics. However, *A. baumannii* has fewer and smaller porins than other Gram-negative bacteria, thereby decreasing cell permeability and increasing antibiotic resistance. (7)

## **Infections Caused by *A. baumannii***

*Acinetobacter baumannii* (formerly *A. calcoaceticus* var. *anitratus* ) is a major cause of nosocomial infections and the second most frequent non-fermenter encountered in clinical laboratories . The sources of *A. baumannii* include soil and foods, it colonizes the skin of healthy humans in low density for a short time. The nature of the organism and its durability as well as its resistance to antibiotics makes it a successful infectious

agent in hospitals. Infections with *A. baumannii* most often occur in critically ill hospitalized patients, mainly in advanced age, immunosuppression and burn injuries. It has been well recognized as a potentially resistant organism, particularly in nosocomial infections. Its resistance pattern usually includes many commonly used antimicrobial agents such as penicillins, cephalosporins, monobactams, aminoglycosides, and fluoroquinolones. Carbapenems (imipenem and meropenem) have often become the drugs of choice for treatment of infections caused by this organism. Carbapenem-resistant *Acinetobacter* has been increasingly reported. Resistance to the carbapenem class of antibiotics makes infections caused by multidrug-resistant *Acinetobacter* difficult if not impossible to treat. The different infections caused by this organism are summarized below:

**Pneumonia:** The infection occurs most commonly during the rainy season in people with a history of alcohol abuse, the elderly and inpatients on respirators. Pneumonia is a major cause of death in hospitalized patients with chronic obstructive pulmonary diseases and the elderly. Large surveillance studies from the United States revealed that 5 to 10% of cases in the ICU are prone to contract pneumonia due to *A. baumannii* (8). Although Community-acquired pneumonia due to *A. baumannii* has worldwide distribution, it is more prevalent in the tropical regions of Australia and Asia (9, 10, 11, 12, and 13).

**Septicemia:** Although *A. baumannii* is the major cause of ICU-acquired bloodstream infections, it is less common in non-ICU wards. The infection is probably associated with catheters. Septicemia ranks as the third highest crude mortality rate in the ICU, exceeded only by infections caused by *P. aeruginosa* and *Candida albicans* (14).

**Wounds:** wound infections usually include burns, wounds inflicted during combat in wars such as that acquired by American soldiers in Iraq and from natural disasters such as hurricanes and earthquakes. This organism caused a percentage of 2.1% of ICU-acquired skin/soft tissue infections (8). *A. baumannii* is a well-recognized pathogen in burn units that may be difficult to eradicate (15). Reports indicated a high frequency of wound infections caused by *A. baumannii* was detected in American soldiers fighting in Iraq or Afghanistan (16,17).

**Urinary Tract Infections:** These type of infections are commonly encountered in patients with catheters colonized by *A. baumannii*. It is not common for this organism to cause UTI in healthy outpatients.

The ability of this organism to cause rare infections such as meningitis subsequent to post-neurosurgical procedures is reported. Patients who developed meningitis had usually undergone neurosurgery and had external ventricular drain (18).

## **Risk factors for acquiring *Acinetobacter baumannii***

There are many factors that predispose infections with *A. baumannii*. These factors include advanced age, antimicrobial therapy within the past 90 days, evidence of high-frequency antibiotic resistance in the community or hospital, severe immunosuppression due to certain diseases or chemotherapy, multiple co-morbid conditions and prolonged hospitalization (especially critical care) or residence in an extended care facility. Use of artificial medical devices may also contribute to contracting infections by this organism. Some of these medical devices are: dialysis, mechanical ventilators, sutures and catheters (central venous, intravenous and urinary).

Pregnant healthcare workers are not at increased risk of becoming infected with this organism, and can therefore care for patients infected or colonized with this organism.

## **Sources of *Acinetobacter baumannii* Transmission in Hospitals**

**Supplies:** Supplies are an important environmental source of this organism. These supplies include crash carts, weighing hammocks, protective masks, shared equipment, invasive equipment and interventions, catheters (ie, central lines, urinary) and administration of medications from multidose vials.

**Room variables:** Room environment is another important source of *A. baumannii*.

Many objects present in hospital rooms may be shared by patients and the medical staff who in turn may spread this durable organism to other patients. Such objects include bed rails, blood pressure cuffs, furniture, door knobs or handles, intravenous stands, linens, foam mattresses, paper towel dispensers, pillows, containers for sharp objects-disposal, sinks, table tops, mechanical equipment, air conditions, hemodialysis machinery, infusion pumps, key panels of monitors, computers, continuous venous hemodialysis machines, mattresses with pneumatic pumps, ventilators and respiratory equipment.

**Liquids:** Body fluids may be considered as a significant source of *A. baumannii*.

Examples of body fluids and other related liquids and fluids include body fluids such as blood products, and other fluids that are commonly used in the hospital and usually introduced intravenously such as normal saline and enteral formulas

as well as other miscellaneous fluids such as soaps, detergents and non-sterile distilled water placed in humidifiers.

## **Epidemiology:**

*A. baumannii* is primarily a healthcare-associated pathogen. It is increasingly reported as the cause of outbreaks and nosocomial infections such as blood-stream infections, ventilator-associated pneumonia, urinary tract infections and wound infections.

*Acinetobacter* isolates demonstrate increasing resistance to commonly prescribed antimicrobials. Multidrug-resistant *A. baumannii* has been reported worldwide and is now recognized as one of the most difficult healthcare-associated infections to control and treat.

Multidrug-resistant (MDR) *Acinetobacter* rarely causes serious infection in healthy people. Sources of outbreaks are frequently detected in intensive-care and burn units involving patients on mechanical ventilators. Transmission of *A. baumannii* during outbreak setting primarily involve respiratory equipment such as resuscitator bags, valves, ventilator circuits, spirometers, peak flow meters and suction catheters. Other sources of transmission may include humidifiers, warming baths, multidose vials, distilled water, pillows, mattresses, bedpans, showers and faucets. In 50% of reported outbreaks caused by *A. baumannii*, the source of transmission was not identified.

An outbreak of MDR *Acinetobacter* at Johns Hopkins Hospital was linked to the use of a pulsatile lavage with suction device used to care for wounds. Widespread environmental contamination and healthcare-associated transmission of the organism occurred during this outbreak. As a result, the Hospital Epidemiology and Infection

Control Department has implemented new infection control precautions for all treatments involving pulsatile lavage suction (19).

### **Antimicrobial susceptibility:**

Minimum Inhibitory Concentrations (MIC) is defined as the lowest concentration of an antimicrobial that inhibits the growth of a microorganism after overnight incubation. Minimum Bactericidal Concentrations (MBC) is defined as the lowest concentration of an antimicrobial that kills 99% of the microorganism when the MIC tube or two dilutions above the MIC is plated on agar media. Antimicrobial susceptibility can be performed by several methods using standardized procedures according to the CLSI. Some of these methods include:

**Reference methods:** Agar dilution, broth dilution (Macro and micro) and disk diffusion by the Kirby-Bauer method.

**Commercial methods** : Manually performed, E-test and dry-form broth microdilution ( long-shelf life ), Automated, Micro Scan, Vitek and Vitek2.

Agar dilution susceptibility testing is the solid equivalent of broth dilution susceptibility testing, either in macro- or micro broth format. The advantage of using the agar dilution method over broth-based dilution methods is that it allows the simultaneous testing of a large number of strains on a single agar plate. A total number of 32 to 37 can be usually placed on one 90 mm agar plate containing a specific concentration of the antibiotic to be tested. Steers-Foltz or a similar replicator (Figure 2) is used in this procedure. This method is therefore well suited for the rapid evaluation of new antibiotics or related compounds for large-scale testing.

Disadvantages of this method include the incorporation of an additional variable (agar), in the medium. In addition, the shelf life of these prepared agar plates is limited owing to dehydration and degradation of the added antimicrobial agents (20).

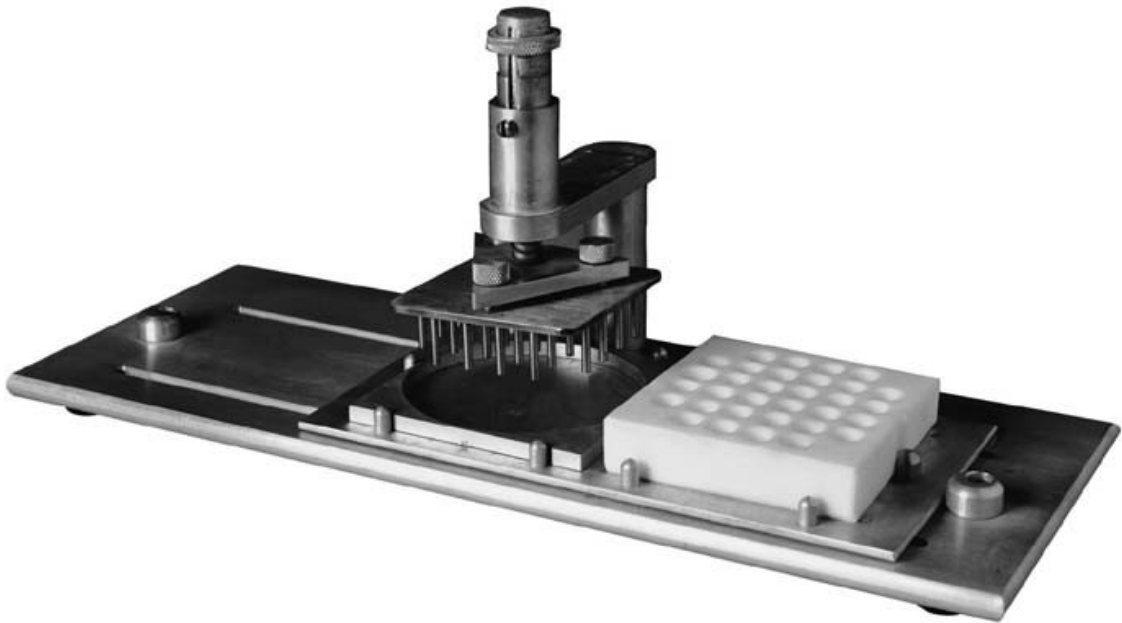

Figure 2. Steer's Replicator

A susceptible result implies that an infection due to the isolate may be appropriately treated with the proper dosage of an antimicrobial agent recommended for this type of infection. A resistant result implies that the isolate is not inhibited by the tested antibiotic indicating the evolution of resistance which may warrant further evaluation. Alternative therapeutic agents must be used for successful treatment of this infection. An intermediate result implies that an infection caused by the isolate may be properly treated by increasing the dosage of the antibiotic to achieve higher concentrations at the infected body site. The category intermediate, constitutes a safety margin or a buffer zone to identify the presence of small, uncontrolled technical factors from causing major discrepancies in interpretations (21).

## Combination Therapy

Combination therapy using two or more antibiotics is primarily used to prevent the emergence of resistant strains. It is also used to treat life threatening infections when the etiological agent is not known yet. In addition, it is essential to use combination therapy to reduce the dosage and avoid the toxic effects of antibiotics as well as to reduce the selection pressure causing the emergence of resistant strains (Figure 3).

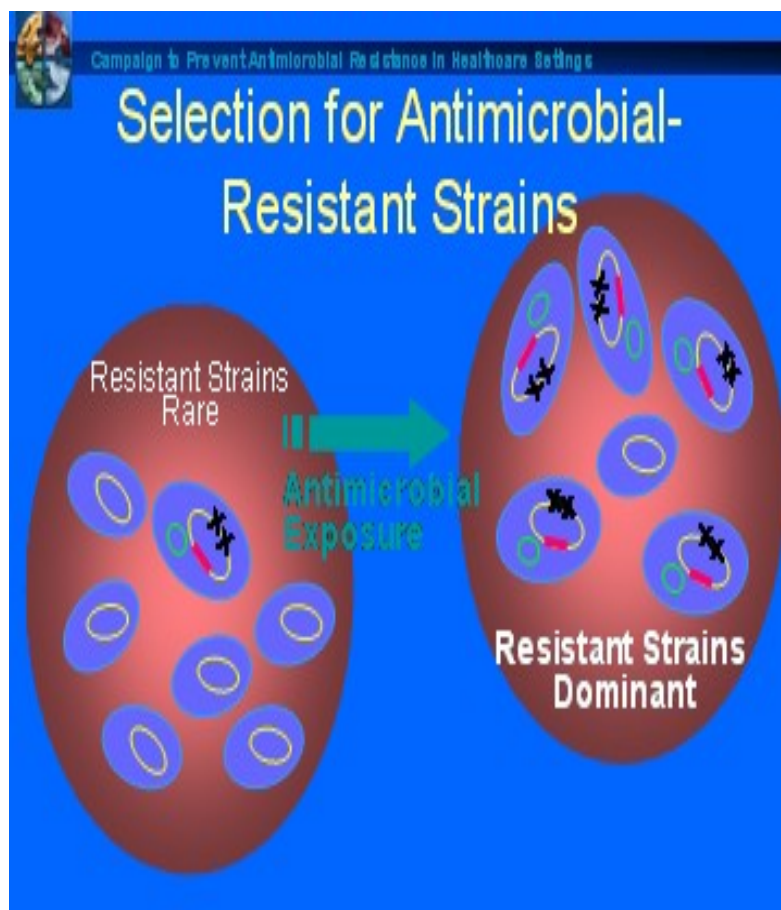

Figure 3. Selection pressure for antimicrobial resistant strains.



Synergy occurs when the effects of combined antibiotics is greater than the sum of the effects of the individual ones. Antagonism occurs when one antibiotic, usually the one with the least effect, interferes with the effects of another antibiotic. Many combinations have been evaluated using in-vitro techniques and animal models (22,23 and 24) including various combinations of quinolones,  $\beta$ -lactams, and/or amino glycosides. Quinolone combination tests using a mouse-pneumonia model, where ciproxin and/or levofloxacin, is combined with imipenem or amikacin gave reduced efficacy with a lack of enhanced activity in *A. baumannii* infected mice (25). Interestingly, enhanced activity was seen when aztreonam was tested in combination with other  $\beta$ -lactams against a selected group of Metallo  $\beta$ -lactamase (MBL) producing *A. baumannii* strains (26). Using a mouse pneumonia model, Montero et al. reported on the potential efficacy of imipenem and rifampin against a carbapenem-resistant and rifampin-resistant *A. baumannii* strain (27).

## **Mechanisms of Resistance:**

To understand the mechanisms of bacterial resistance, it is necessary to understand bacterial physiology, the pharmacology of antimicrobial drugs, and the molecular biology of infectious agents. The genes responsible for resistance mechanisms may be located either on the chromosome or on extra-chromosomal elements such as plasmids. Plasmids are circular pieces of DNA that replicate autonomously and independently of the chromosome. The practical significance of the difference is that the chromosomal DNA is relatively stable whereas the plasmid DNA is easily mobilized from one strain to another. In addition, the linking of resistance genes for

multiple antibiotics on a plasmid allows transfer of resistance to newly characterized resistant organisms.

The most common mechanism for transferring resistant genes is conjugation. An additional genetic transfer factor is necessary before a plasmid that carries a resistant gene can move from one organism to another. Recently, transposon (transposable genetic element) is considered the most delineated transfer mechanism. Transposons can carry portions of plasmids and more importantly, they can carry a piece of the chromosome from one bacterium to another by conjugal transfer (conjugative transposon or jumping gene).

Resistance can be caused by several mechanisms (4):

- The presence of an enzyme that inactivates the antimicrobial agent.
- The presence of an alternative enzyme that replaces the enzyme inhibited by the antimicrobial agent.
- A mutation in the antimicrobial agent's target producing an altered, which reduces the binding of the antimicrobial agent.
- Posttranscriptional or posttranslational modification of the antimicrobial agent's target, which reduces binding of the antimicrobial agent.
- Reduced uptake of the antimicrobial agent due to influx associated problems..
- Active efflux of the antimicrobial agent.
- Overproduction of the target of the antimicrobial agent.

Other mechanisms of resistance to antibiotics may still be unrecognized.

On the other hand, a gene which is not expressed in vitro may be expressed in vivo.

A resistance mechanism may be expressed continuously whether an inciting challenge is present or not. This is referred to as constitutive expression. In contrast, some genes must be induced to produce their product after exposure to the challenge substance. Most of the enzymes of gram- negative bacteria are cell bounded so that they exert their effects only if the antibiotic enters the bacterial cell (28).

## **Antibiotic resistant genes in MDR *Acinetobacter baumannii***

### **CARBAPENEM:**

**Mode of action:** It inhibits bacterial cell wall synthesis similar to other beta-lactam antibiotics. In contrast to other beta-lactams, it is highly resistant to degradation by beta-lactamases or cephalosporinases (Figure 4).

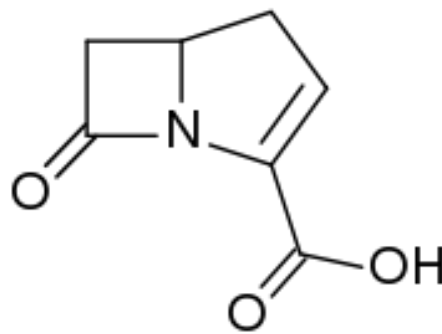

Figure 4. Structure of carbapenem backbone

### **Resistance to carbapenems:**

Resistance generally arises due to mutations in penicillin binding proteins, production of metallo-beta-lactamases, or resistance to diffusion across the bacterial outer membrane.

Of the  $\beta$ -lactamases, the carbapenemases are the most prevalent. These include the serine oxacillinases (Ambler class D OXA type) and the metallo-lactamases (MBLs) (Ambler class B) (29, 30 and 31). Thus far, the Ambler class A carbapenemases (KPC, GES, SME, NMC, and IMI) have not been described for *A. baumannii* (30). MBLs are being less commonly identified in *A. baumannii* than the OXA-type carbapenemases. The hydrolytic activities of OXA-type toward carbapenems are significantly more potent (100- to 1,000-fold) (29). These enzymes have the capability of hydrolyzing all  $\beta$ -lactams (including carbapenems) except the monobactam aztreonam, which may assist in laboratory detection of resistant strains. Of the five MBL groups described to date, only three have been identified in *A. baumannii*, including IMP, VIM, and SIM types (31). Four groups of carbapenem-hydrolyzing oxacillinases have been described in *A. baumannii*:

The first group consists of OXA-23, OXA-27 and OXA-49 which have 99% amino acid homology. The gene encoding for this group is known as *bla* OXA-23 (32).

The second group consists of OXA-24, OXA-25, OXA-26, and OXA-40. This group shares 60% homology with the first group. Variations among these enzymes are due to few amino acid substitutions. The gene encoding for this group is known as *bla* OXA-40. (32 and 33).

The third group consists of  $\beta$ -lactamase OXA-51, which shares less than 63% amino acid homology with the other two groups. OXA-51 has been recently identified in *A. baumannii* isolates from Argentina and not associated with resistancy. The gene encoding for this group is known as *bla* OXA-

The fourth group consists of the most recently discovered enzyme OXA-58, which is less common and associated with resistancy. The gene encoding for this group is known as *bla* OXA-58. (32 and 34).

The first description of an OXA carbapenemase in *A. baumannii* was OXA-23. It was detected in a clinical isolate in Scotland in 1985 before the introduction of carbapenems. Since then, this plasmid-encoded enzyme, initially named ARI-1 (acinetobacter resistant to imipenem) has been also discovered in England, Brazil, Polynesia, Singapore, Korea, and China (35 and 36). OXA-24-like enzymes were detected in isolates epidemiologically linked to Spain and Portugal since 1996 (37, 38). OXA-51 and OXA-58 were the most recent discoveries. The first known OXA-58-producing *Acinetobacter* isolate was collected in France in 2003 (39).

Subsequently, this enzyme was found in an outbreak-strain in a French hospital (40) and in isolates from several southern and eastern European countries. A plasmid-borne OXA-58 carbapenemase, was found in strains isolated in England, Argentina, Spain, Turkey, Romania, Austria, Greece, Scotland, and Kuwait ( 41,42 ).



Figure 5. Countries that have reported an outbreak of carbapenem-resistant *Acinetobacter baumannii*. Red signifies outbreaks reported before 2006, and yellow signifies outbreaks reported since 2006 (51).

## FLUOROQUINOLONES

**Mode of action:** Quinolones bind to the A subunit of DNA gyrase (topoisomerase) and prevent supercoiling of DNA, thereby inhibiting DNA synthesis.

Fluoroquinolones (Figure 6) exert their antibacterial effects by inhibition of certain bacterial topoisomerase enzymes, namely, DNA gyrase (bacterial topoisomerase II) and topoisomerase IV. These essential bacterial enzymes alter the topology of double-stranded DNA (dsDNA) within the cell. DNA gyrase and topoisomerase IV are heterotetrameric proteins composed of two subunits, designated A and B. The genes encoding the two A and two B subunits are referred to as *gyrA* and *gyrB* (DNA gyrase) or *parC* and *parE* (DNA topoisomerase IV). DNA gyrase is the only enzyme that can affect supercoiling of DNA (28). Inhibition of this activity by

fluoroquinolones is associated with rapid killing of the bacterial cell. Topoisomerase IV can also modify the topology of dsDNA. While DNA gyrase seems to be important for maintenance of supercoiling, topoisomerase IV is predominantly responsible for the separation of daughter DNA strands during cell division (43).

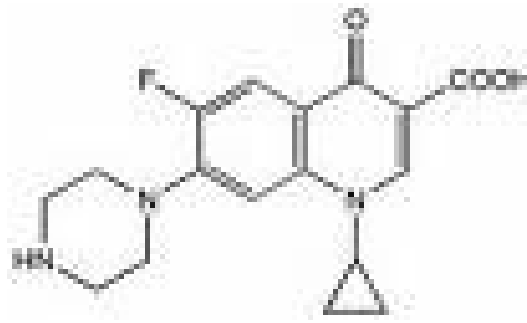

Figure 6. Structure of quinolone backbone

### **Resistance to Fluoroquinolones:**

There is a region in the genes responsible for quinolone resistance known as Quinolone Resistance Determining Region (QRDR). The mutations that play the most important role in the acquisition of resistance to quinolones located in the QRDR occur on the *gyrA* and *parC* genes. Mutations affecting the QRDR of the *gyrB* gene seem to be more frequent in quinolone-resistant strains obtained in vitro than in clinical isolates. Mutations affecting the *parE* gene are extremely unusual among clinical isolates of Gram-negative bacteria. Many studies were conducted on *A. baumannii* to investigate mutations that occur in QRDR, specifically in *ParC* and *gyrA*. These studies were done in Spain, France, USA, UK and Israel (44 and 45) Variable results were obtained from these studies, but all confirmed the presence of mutations in *gyrA* resulting in resistance to quinolones regardless of the MIC levels.

Double mutations in *gyrA* and *parC* genes correlated with elevated MICs. It has been found that the amino acid residues most frequently mutated in *gyrA* occur at serine 83 and glycine 84, these are the hotspots for mutation associated with resistance to ciprofloxacin. The hotspots for mutations in *parC* genes occur at serine 80 and glutamate 84. Mutations at other sites of *ParC* were identified in other studies but with less frequency (44.45 and 46).

## AMINOGLYCOSIDES

**Mode of action:** The aminoglycosides irreversibly bind to the 30S ribosomes and freeze the 30S initiation complex (30S-mRNA-tRNA), inhibiting the initiation of protein synthesis. In addition, aminoglycosides can also slow down protein synthesis during the occurrence of initiation inducing misreading of the mRNA.

Aminoglycosides ( Figure 7) such as gentamicin, tobramycin, amikacin, and streptomycin are commonly used antimicrobial agents in the treatment of infections caused by both gram-negative and gram positive organisms.

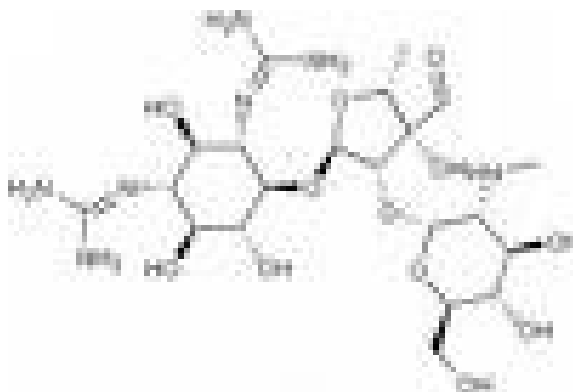



Figure 7. Structure of aminoglycoside backbone

**Resistance to aminoglycosides:**

Resistance to these antimicrobial agents is widespread. More than 50 aminoglycoside-modifying enzymes are already described. The genes encoding for these modifying enzymes are associated with gram-negative bacteria. Depending on the type of modification, these enzymes are classified as aminoglycoside acetyltransferases (AAC), aminoglycoside adenylyltransferases also named aminoglycoside nucleotidyltransferases (ANT), and aminoglycoside phosphotransferases (APH). The position of the modification on the substrate is denoted by a number with or without a prime or double prime. Sub-classification of these enzymes depends on the aminoglycoside substrates that are modified. The gene designations follow this pattern, but a further sub-classification is made when different genes encode enzymes that have the same substrate profile. Aminoglycosides modified at amino groups by AAC enzymes or at hydroxyl groups by ANT or APH enzymes lose their ribosome-binding ability and thus no longer inhibit protein synthesis (47).

In addition to aminoglycoside-modifying enzymes, efflux systems and rRNA mutations have also been described to play a role in the organism's resistance to this type of antimicrobial agents (48). The enzymes that are most commonly responsible for resistance in microorganisms to aminoglycosides include Phosphotransferase gene (alpha A6), adenylyltransferase genes (aadA1 and aadB) and acetyltransferase genes (aacC1 and aacC2) (49).

**CEPHALOSPORINS**

**Mode of action:** Similar to other beta-lactam antibiotics, (Figure 8) such as penicillins, cephalosporins have the same bactericidal mode of action. Cephalosporins disrupt the synthesis of the peptidoglycan layer in the bacterial cell walls. The peptidoglycan layer is responsible for cell wall structural integrity. The final step in the synthesis of the peptidoglycan layer, transpeptidation, is facilitated by transpeptidase enzymes known as Penicillin Binding Proteins (PBPs). PBPs bind to the terminal D-Ala-D-Ala at the end of peptide chain (peptidoglycan precursors) to crosslink the peptidoglycan layers together. Beta-lactam antibiotics have structural similarity to the D-ALA-D-Ala terminal end of the peptide chain normally present in the peptidoglycan component of the bacterial cell wall. Therefore, they compete with the PBPs to bind to this site, thus disrupting the formation of the peptidoglycan layer in the bacterial cell wall.

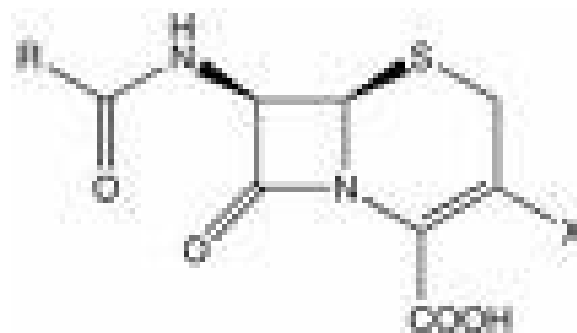

Figure 8. Structure of Cephalosporin backbone

**Resistance to cephalosporins:** The most prevalent mechanism of resistance in *A. baumannii* to  $\beta$ -lactam antibiotics is mediated by the enzymatic degradation of the beta-lactam ring by  $\beta$ -lactamases. However, in keeping with the complex nature of this organism, multiple mechanisms of resistance may often work in concert to

produce the same resistant phenotype. Inherent to all *A. baumannii* strains are chromosomally encoded AmpC cephalosporinases, also known as *Acinetobacter*-derived cephalosporinases (ADCs) (50). Over expression of these enzymes in *A. baumannii* is regulated by a key determinant, an upstream IS element known as ISAba1. The presence of this element highly correlates with increased AmpC gene expression and resistance to extended-spectrum cephalosporins. Cefepime and carbapenems appear to be stable in response to these enzymes.

Extended-spectrum  $\beta$ -lactamases (ESBLs) belonging to the Ambler class A group have also been described for *A. baumannii*. Assessment of their true prevalence is hindered by difficulties with laboratory detection, especially in the presence of an AmpC. Recently more focus has been placed on VEB-1,(VEB-1a) ; PER-1, and PER-2 . Other ESBLs identified in *A. baumannii* include TEM-92, TEM-116 and SHV-12 (51) as well as CTX-M-2 and CTX-M-43. Narrow-spectrum  $\beta$ -lactamases such as TEM-1 and TEM-2, are also prevalent in *A. baumannii*, but their current clinical significance is limited given the potency of other resistance determinants (51).

## Treatment

*A. baumannii* is intrinsically multidrug resistant. Relatively few antibiotics are active against this organism. While colonization should not be treated, infections with this organism should be treated. Antibiotics to which *Acinetobacter* is usually sensitive include meropenem, colistin, polymyxin B, amikacin, rifampin and tigecycline. First, second and third-generation cephalosporins, macrolides, and penicillins have little or no anti-*Acinetobacter* activity. Their use may predispose to *Acinetobacter*

colonization. Although meropenem was the drug of choice to treat infections caused by *A. baumannii*, resistant strains to carbapenems have been encountered. Therefore, older polymyxin antibiotics such as colistin, polymyxin E and polymyxin B have been evaluated. Polymyxins were discovered and isolated from *Bacillus polymyxa* in 1947. The polymyxin structure consists of a fatty-acid side chain attached to a polycationic-peptide ring made up of 8 to 10 amino acids, allowing polymyxins to be amphipathic, permitting them to be water (or blood) soluble as well as in the lipid bilayer present in prokaryotic and eukaryotic cell membranes (Figure 9).

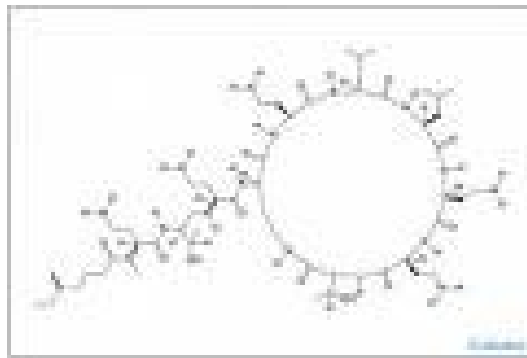

Figure 9. Structure of Colistin backbone

The mechanism of action of Polymyxins is unique in that it causes disruptive physiochemical effects on the cell membrane and it is not susceptible to changes in the organism's metabolic activity. This mechanism is achieved by displacing the organism's calcium and magnesium bridges that stabilize the lipopolysaccharide (LPS) molecules. This destabilization causes a negative charge on the LPS, resulting in a more permeable membrane and allowing the leakage of bacterial contents. In addition, polymyxins have potent antiendotoxin activity, allowing them to avoid neutralization by the gram negative bacteria. Polymyxins are known to be bacteriostatic at low concentrations and bactericidal at high concentrations.

Nephrotoxicity and neurotoxicity have been the cause of polymyxins' notoriety and decreased use in treating infections (52).

However, newer agents are now available that may add to the treatment armamentarium against MDR. Tigecycline (Figure 10) is a relatively new FDA-approved antimicrobial agent used to treat poly-microbial infections in complicated skin and intra-abdominal infections. It may also be used in cases where deep tissue penetration is needed, or where multi-drug resistant pathogens are suspected. Tigecycline has good in vitro activity against imipenem-resistant pathogens showing 100% sensitivity.

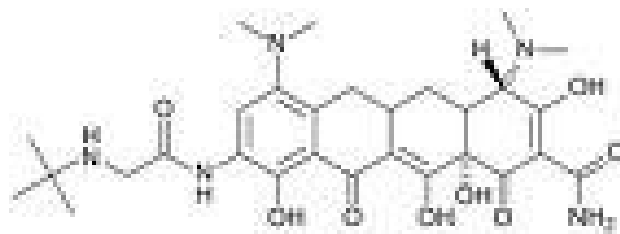

Figure 10. Structure of Tigecyclin backbone

## Prevention

**Isolation:** Patient-isolation precautions are designed to prevent transmission of microorganisms by common routes in hospitals. Because agent and host factors are more difficult to control, interruption of the spread of microorganisms is directed primarily at transmission.

**Handwashing:** Handwashing is frequently called the single most important measure to reduce the risks of transmitting microorganisms from one person to another or from

one site to another on the same patient. Washing hands as promptly and thoroughly as possible between patient contacts and after contact with blood, body fluids, secretions, excretions, and contaminated equipment or articles is an important component of infection control and isolation precautions. Although handwashing may seem like a simple procedure, it is often performed incorrectly. Healthcare settings must continually remind practitioners and visitors on the proper procedure in washing their hands to comply with effective hand-washing practices.

**Visitors:** In order to adequately control the spread of infections, all visitors must follow the same precautionary measures as hospital staff. Visitors and healthcare personnel are equally to blame in transmitting infections. Moreover, multi-drug resistant infections can leave the hospital and become part of the community flora if the necessary steps are not taken in consideration to curb their transmission.

**Gloves:** In addition to handwashing, gloves play an important role in reducing the risks of transmission of microorganisms. Gloves provide a protective barrier and prevent gross contamination of the hands when touching blood, body fluids, secretions, excretions, mucous membranes and skin. They can reduce the chance that microorganisms present on the hands of the medical staff will be transmitted to patients during invasive or other patient-care procedures that involve touching a patient's mucous membranes and nonintact skin. Gloves can also reduce the chance of cross contamination between the medical staff and patients. Gloves must be changed between patient's contacts and hands must be washed after their removal. Gloves does not replace the need for handwashing, they may have small, non-apparent pores where hands can become contaminated. Failure to change gloves between patient contacts is an infection control hazard.

**Aprons:** Wearing an apron during patient care reduces the risk of infection. The apron should either be disposable or be used only when caring for a specific patient under specific circumstances.

### **Aims of the study:**

*Acinetobacter baumannii* has emerged as a major nosocomial pathogen. Meropenem and imipenem are the most commonly used antimicrobials to treat infections inflicted by this pathogen. Recently, resistance mechanisms have evolved causing this microorganism to become resistant to these antibiotics. Our aims of this study were:

- To determine the antimicrobial susceptibility of *Acinetobacter baumannii* isolates.
- To determine the minimum inhibitory concentration of *A. baumannii* isolates to meropenem, ciproxin and colistin individually and meropenem and ciproxin in combination using the agar dilution method.

- To evaluate the resistance of this organism to fluoroquinolones by PCR. Mutations on the *gyrA* and *parC* genes will be determined.
- To evaluate the presence of carbapenemase resistant genotypes by PCR. The presence of the oxacillinase genes OXA-23, OXA-24, OXA-51 and OXA-58 will be determined.

## **Materials and Methods**

### **Specimens collection:**

Eighty five clinical isolates of *A. baumannii* were recovered from inpatients at Makassed Islamic Hospital in Jerusalem from January to December in the year 2007. The isolates were stored at -20°C containing glycerol (10%) before the start of this study. The BBL-crystal Enteric/Nonfermentor system (Becton, Dickinson and company, Boston) was used to identify all isolates. The isolates were collected from different wards in the hospital: 22 (26%) isolates from neonate intensive care unit, 12



(14%) from surgical ward, 11 (13%) from orthopedic ward, 9 (10.5%) from medical ward, 9 (10.5%) from pediatric intensive care unit, 8 (9.4%) from adult intensive care unit, 6 (7%) from pediatric ward, 4 (4.7%) from open heart ward, 1 (1.2%) from cardiac care unit, 1 (1.2%) from maternal ward and 2 (2.3%) from emergency. The total outcome of 52% of the isolates was from intensive care units (Fig 11). The isolated were collected from different sources: Blood, wounds, sputum, urine, nasal, eyes, rectal and catheters.

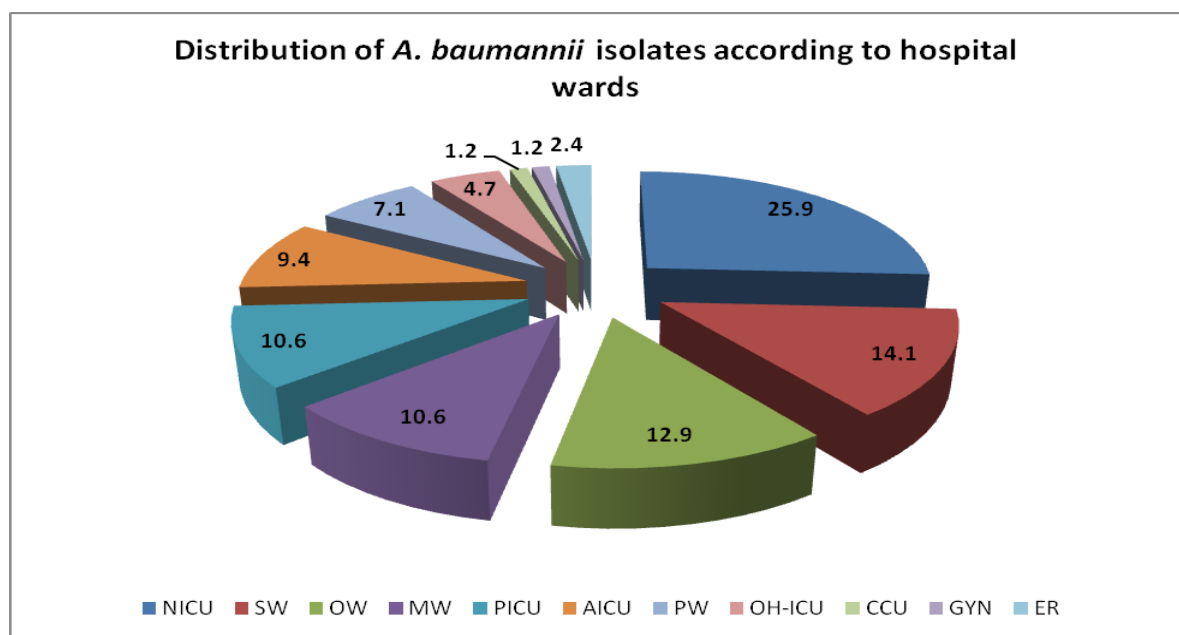

Figure 11: Distribution of *A. baumannii* isolates according to hospital wards at Makassed Charitable Hospital.

NICU: Neonate intensive care unit, SW: Surgical ward, OW: orthopedic ward, MW: Medical ward, PICU: Pediatric intensive care unit, AICU: Adult intensive care unit, PW: Pediatric ward, OH-ICU: Open heart-intensive care unit, CCU: cardiac care unit, GYN: Gynecology ward, ER: Emergency room.

### Antimicrobial Susceptibility Testing:

MICs for meropenem (Dy223, AstraZeneca UK limited) and ciproxin (CRP5641203

Birzeit Pharmaceutical company) were individually determined by agar dilution

according to Clinical Laboratory Standard Institute (CLSI) using 0.5 McFarland

inoculum and the Steers-Replicator (Figure 2). This allowed the testing of a total of

37 microorganisms simultaneously on a single agar plate (Figure 12). Antibiotic-

standard powders of meropenem with potency of 74% and ciproxin with potency of 99.8% were used. The concentrations tested for meropenem were: 0.5, 1, 2, 4, 8, 16, 32, 64, 128 and 246 µg/ml and for ciproxin were: 0.25, 0.5, 1, 2, 4, 8, 16, 32, 64 and 128 µg/ml. The checkerboard panel method was used for the MIC determination of meropenem/ciproxin combinations (Table 1). The interpretation of the antimicrobial combinations was done by reading the first clear spot as shown in Figure 12 in each row of the panel with both agents. Based on this reading, Fractional Inhibitory Concentrations (FICs) were calculated for each antimicrobial alone and in combination. The following formulas were used to calculate the FIC:

FIC of meropenem = MIC of meropenem in combination / MIC of meropenem alone.

FIC of ciproxin = MIC of ciproxin in combination / MIC of ciproxin alone.

FIC Index ( $\Sigma$ FIC) = FIC of meropenem + FIC of ciproxin.

FIC index results for each combination were interpreted as:

Synergy: if the decrease in the MIC of each agent was  $\geq 4$ -fold ( $\Sigma$ FIC  $\leq 0.5$ ).

Partial synergy: if the decrease in the MIC of one agent was  $\geq 4$ -fold and the decrease in the MIC of the other agent was 2-fold ( $\Sigma$ FIC  $> 0.5$  and  $< 1$ ).

Additive: if the decrease in the MIC of both agents was 2-fold ( $\Sigma$ FIC = 1).

Indifference: if the interactions did not meet the above criteria and were not antagonistic ( $\Sigma$ FIC  $> 1$  and  $< 4$ ).

Antagonism: if an increase in the MIC of both agents was  $\geq 4$ -fold ( $\Sigma$ FIC  $\geq 4$ ).

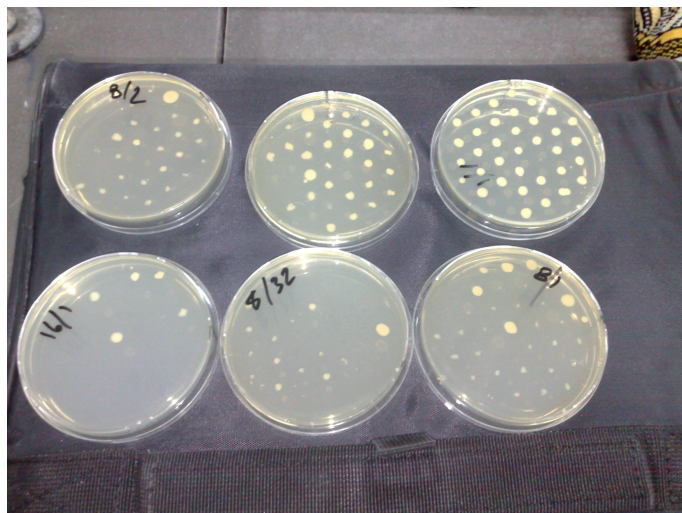

Figure 12. Representative plates for antimicrobial susceptibility by the agar dilution method using Steer's replicator (not sequential).

Cip/Mer μg/ml	Antibiotic Combination							
	128	64	32	16	8	4	2	1
64	64/128	64/64	64/32	64/16	64/8	64/4	64/2	64/1
32	32/128	32/64	32/32	32/16	32/8	32/4	32/2	32/1
16	16/128	16/64	16/32	16/16	16/8	16/4	16/2	16/1
8	8/128	8/64	8/32	8/16	8/8	8/4	8/2	8/1
4	4/128	4/64	4/32	4/16	4/8	4/4	4/2	4/1
2	2/128	2/64	2/32	2/16	2/8	2/4	2/2	2/1
1	1/128	1/64	1/32	1/16	1/8	1/4	1/2	1/1
0.5	0.5/128	0.5/64	0.5/32	0.5/16	0.5/8	0.5/4	0.5/2	0.5/1

Table 1: Checkerboard used to test combination of meropenem and ciproxin.  
Rows: meropenem, Columns: Ciproxin.

In addition, the MIC of colistin sulfate (C4461 SIGMA) was determined using the same procedure as above, the potency of colistin sulfate powder was 99.8%. The concentrations tested for colistin were: 0.25, 0.5, 1, 2, 4, 8 and 16 μg/ml.

### PCR Amplification, DNA Sequencing, and Restriction Endonuclease Digestion

Extraction of DNA for PCR:

Isolates were grown overnight on BAP at 37°C. Five to ten colonies of each isolate were removed with a sterile loop and emulsified in 100 µl of sterile distilled water in a 0.2 ml Eppendorf tube. Lyses was achieved by heating the tube for 10 minutes at 95°C in a water bath. The tube was then centrifuged at 13,000 rpms (4).

Amplification was then performed with 5 µl of the supernatant as the DNA template in 25 µl reaction volume. The complete mix consisted of the following components: 12.5µl Go Taq Green Master Mix, 2X (Promega), 0.3 µl upstream primer (0.1µM), 0.3 µl downstream primer (0.1µM), and 6.9µl nuclease free water All primers used for PCR amplification are listed in Table 2.

The amplification conditions were as follows: an initial denaturation step at 95° C, for 5 minutes, 30 cycles of: 94° C for 40 seconds, annealing for 40 seconds at primer set specific temperature (Table 2) and extension at 72° C for 40 seconds. This was followed by a final extension step at 72° C for 10 minutes. A negative control of sterile distilled water was included with every PCR. Positive controls used were selected from strains tested in this project. A 100-bp DNA ladder (Thermo) was used to assess the size of PCR products. PCR products were resolved on 2.0 % agarose gels, stained with ethidium bromide and visualized on UV transilluminator, and selected gels were photographed.

Digestion of *parC* and *gyrA* PCR products were performed as follows 10µl of the PCR products were incubated for 1 hour with 1µl *HinfI* ( TAKARA) , 2µl of 10X H-buffer and 7µl sterilized distilled water . The digestion products were separated by electrophoresis in 2% agarose gel.

Representative PCR products for some isolates were purified and sequenced at Bethlehem University for the oxallinase genes. Also representative PCR products of

*gyrA* and *parC* genes were selected according to their MICs and the results of RFLP were sequenced at Bethlehem University. The sequences obtained were read using Chromas version 2.33 software and were analyzed by the blast online search facility at <http://www.ncbi.com> and [www.srs.ebi.ac.uk](http://www.srs.ebi.ac.uk).

Primer Name	Sequence 5' to 3'	Annealing Tem. (°C)	Target gene	Manufacturer
<i>gyrA-F</i>	AAATCTGCCCGTGTTCGTTGGT	55	<i>gyrA-QRDR</i>	Synteza
<i>gyrA-R</i>	GCCATACCTACGGCGATAACC	55	<i>gyrA-QRDR</i>	Synteza
<i>ParC-F</i>	AAAAATCAGCGCGTACAGTG	53	<i>parC-QRDR</i>	invitrogen
<i>ParC-R</i>	CGAGAGTTTGGCTTCGGTAT	53	<i>parC-QRDR</i>	invitrogen
<i>Oxa51-F</i>	TAATGCTTTGATCGGCCTTG	52	<i>bla<sub>OXA-51</sub></i>	invitrogen
<i>Oxa51-R</i>	TGGATTGCACTTCATCTTGG	52	<i>bla<sub>OXA-51</sub></i>	invitrogen
<i>Oxa58-F</i>	AAGTATTGGGGCTTGTGCTG	50	<i>bla<sub>OXA-58</sub></i>	invitrogen
<i>Oxa58-R</i>	CCCCTCTGCGCTCTACATAC	50	<i>bla<sub>OXA-58</sub></i>	invitrogen
<i>Oxa23-F</i>	GATCGGATTGGAGAACCAGA	50	<i>bla<sub>OXA-23</sub></i>	invitrogen
<i>Oxa23-R</i>	ATTTCTGACCGCATTTCAT	50	<i>bla<sub>OXA-23</sub></i>	invitrogen
<i>Oxa24-F</i>	GGTTAGTTGGCCCCCTTAAA	54	<i>bla<sub>OXA-24</sub></i>	invitrogen
<i>Oxa24-R</i>	AGTTGAGCGAAAAGGGGATT	54	<i>bla<sub>OXA-24</sub></i>	invitrogen

Table 2: Primers and annealing temperatures used for the amplification of genes in *A. baumannii* isolates.

## Results

### Antimicrobial Susceptibility Testing

Antimicrobial susceptibility testing was performed for all bacterial strains by disc diffusion method following the guidelines of CLSI. Minimal inhibitory concentrations for *A. baumannii* isolates against ciproxin, imipenem and colistin were performed using the agar dilution method. The results obtained are summarized in Tables 3, 4 and 5 and Figures 13 and 14. Interpretations of the results were done according to the CLSI recommendations. The MIC for ciproxin was considered sensitive at  $\leq 1$  ug/ml, intermediate at 2 ug/ml and resistant at  $\geq 4$  ug/ml as shown in Table 3. The MIC for meropenem was considered sensitive at  $\leq 4$  ug/ml, intermediate at 8 ug/ml and resistant at  $\geq 16$  ug/ml as shown in Table 4. At present, there is no agreement on how to interpret resistance for colistin. The Société Française de Microbiologie uses a cut off of 2.0 mg/l, whereas the British Society for Antimicrobial Chemotherapy sets a cutoff of 4.0 mg/l or less as sensitive, and 8 mg/ml or more as resistant as shown in Table 5. So far, there are no current US standards for interpreting susceptibility for colistin.

There results obtained revealed that 86% (73/85) of the isolates were resistant to ciproxin, and 14% (12/85) were susceptible and none were intermediate as shown in Figure 13.

	MIC $\mu\text{g}/\text{ml}$ for ciproxin										
	0.25	0.5	1.0	2.0	4.0	8.0	16	32	64	128	Total
N	10	0	2	0	18	24	5	5	12	9	85
%	11.8	0	2.4	0	21.2	28.2	5.9	5.9	14.1	10.6	100%
Interpretation	S	S	S	I	R	R	R	R	R	R	

Table3. *A. baumannii* (n=85) MIC ranges and distributions for ciproxin by agar dilution. (S: sensitive, I: intermediate, R: resistant).

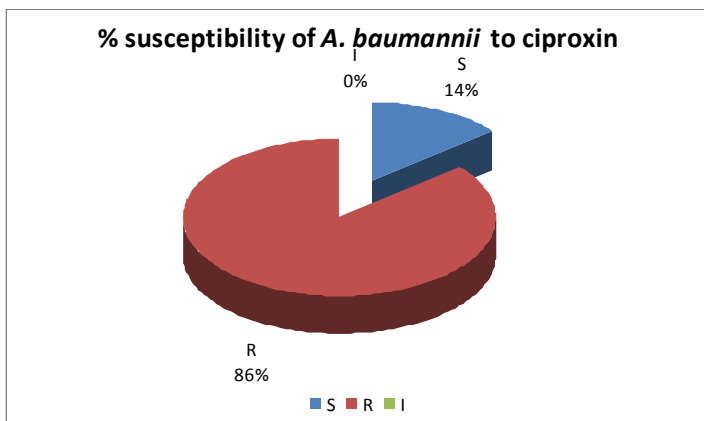

Figure 13. Percent susceptibility of *A. baumannii* to ciproxin.

There were 65.9% (56/85) of the isolates resistant to meropenem, 3.5% (3/85) intermediate and 30.6% (26/85) susceptible as shown in Figure 14

	MIC $\mu\text{g}/\text{ml}$ for Meropenem										Total
	0.5	1.0	2.0	4.0	8.0	16	32	64	128	265	
<b>N</b>	10	8	8	0	3	2	2	5	41	6	85
<b>%</b>	11.8	9.4	9.4	0	3.5	2.4	2.4	7.1	48	7.1	100%
<b>Interpretation</b>	S	S	S	S	I	R	R	R	R	R	

Table 4 *A. baumannii* (n=85) MIC ranges and distributions for meropenem by agar dilution.

S: sensitive, I: intermediate, R: resistant



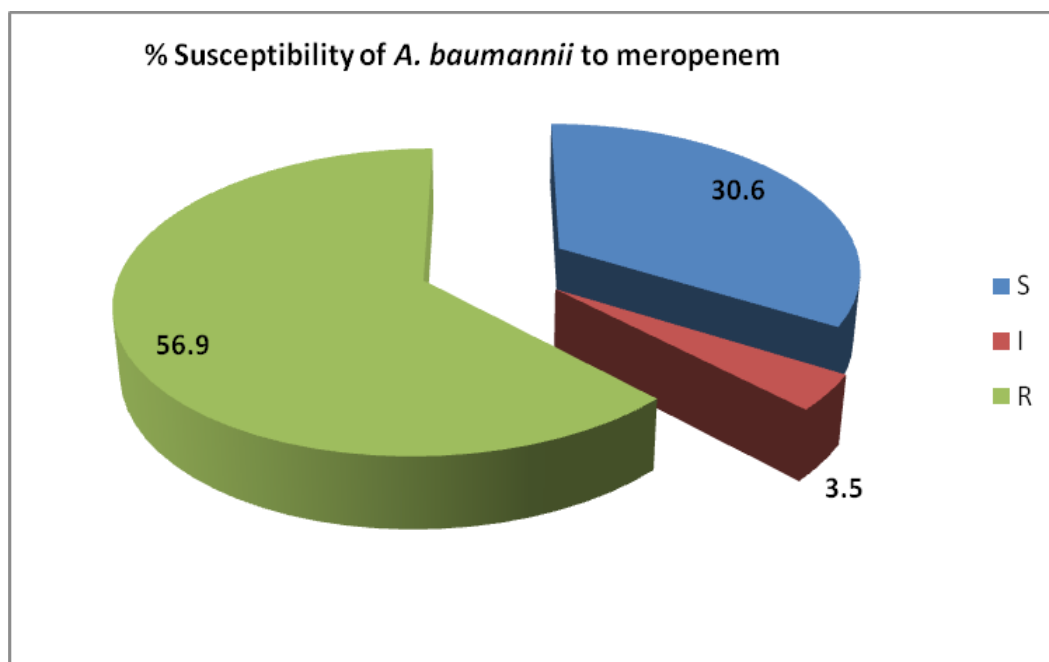

Figure 14. Percent susceptibility of *A. baumannii* to meropenem.  
S: Sensitive, I: intermediate, R: resistant

For colistin, 100% (85/85) or all isolates were susceptible as shown in Table 5

MIC $\mu\text{g}/\text{ml}$ for Colistin sulfate						
	0.25	0.5	1.0	2.0	4.0	Total
<b>N</b>	6	71	6	2	0	85
<b>%</b>	7.1	83.5	7.1	2.3	0	100%
<b>Interpretation</b>	S	S	S	S	R	

Table 5. *A. baumannii* (n=85) MIC ranges and distributions for colistin sulfate by agar dilution. (S: sensitive, I: intermediate, R: resistant).

The MIC<sub>50</sub> and MIC<sub>90</sub> were determined for each of the three antibiotics tested as shown in Table 6 and compared as shown in Figure 15.

	<b>Meropenem</b>	<b>Ciproxin</b>	<b>Colistin sulfate</b>
<b>MIC<sub>50</sub> (µg/ml)</b>	128	8	0.5
<b>MIC<sub>90</sub> (µg/ml)</b>	128	64	0.5
<b>S %</b>	30.6	14.1	100
<b>I %</b>	3.5	0	0
<b>R %</b>	65.9	85.9	0

Table 6. *A. baumannii* isolates susceptibility to Meropenem, Ciproxin and Colistin sulfate (MIC<sub>50</sub>, MIC<sub>90</sub>, sensitive, intermediate and resistant percentages).

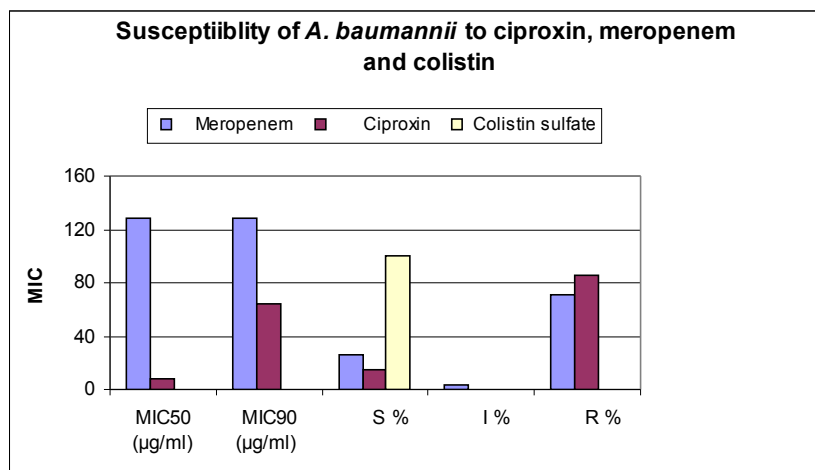

Figure 15. Comparison of the antimicrobial susceptibility of *A. baumannii* to ciproxin, meropenem and colistin.

Note: MIC<sub>50</sub> and MIC<sub>90</sub> for colistin are not apparent in this figure because their values were 0.5 µg/ml

## Synergy testing

The presence of synergy between meropenem and ciproxin was evaluated using different combinations of the two antibiotics by the agar dilution method. The outcome of this experiment is shown in Table 7 and Figure 16, delineating the percentage of isolates with synergistic, partially synergistic, additive, indifferent, or antagonistic combinations for meropenem and ciproxin. The MIC ranges of the different strains to different combinations of meropenem and ciproxin are shown in Tables 8 and 9 .

Examples of calculating the combination outcomes of the two tested antibiotics (ciproxin and meropenem) are stated as follows:

### **Antagonism:**

Isolate 75 had MIC of 0.25  $\mu$ /ml (sensitive) for ciproxin and 0.5  $\mu$ /ml ( sensitive) for meropenem. The combination of both drugs was antagonistic with ciproxin at 0.5  $\mu$ g/ml and meropenem at 2  $\mu$ g/ml ( $\Sigma$ FIC = 6)

### **Synergy:**

Isolate 60 had MIC of 64  $\mu$ g/ml (resistant) for ciproxin and 32  $\mu$ g/ml ( resistant) for meropenem. The combination of both drugs was synergistic with ciproxin at 8  $\mu$ g/ml and meropenem at 4  $\mu$ g/ml ( $\Sigma$ FIC = 0.25)

### **Partial Synergy:**

Isolate 39 had MIC of 4 µg/ml (resistant) for ciproxin and 64 µg/ml (resistant) for meropenem. The combination of both drugs was partial synergy with ciproxin at 0.5 µg/ml and meropenem at 32 µg/ml ( $\Sigma$ FIC = 0.5).

**Indifference:**

Isolate 47 had MIC of 1 µg/ml (sensitive) for ciproxin and 32 µg/ml (resistant) for meropenem. The combination of both drugs was indifference with ciproxin at 0.5 µg/ml and meropenem at 32 µg/ml ( $\Sigma$ FIC = 1.5).

**Additive:**

Isolate 69 had MIC of 4 µg /ml (resistant) for ciproxin and 128 µg /ml (resistant) for meropenem. The combination of both drugs was additive with ciproxin at 2 µg/ml and meropenem at 64 µg /ml ( $\Sigma$ FIC = 1).

<b>Outcome</b>	<b>n</b>	<b>%</b>
Synergy	8	9.5
Partial synergy	44	52
Additive	1	1.2
Indifference	19	22.6
Antagonism	12	14.3
Total	85	100

Table7. Frequency (%) of combination outcomes (synergy, partial synergy, additive, indifference and antagonism) for all clinical isolates (n=85) of *A. baumannii*.

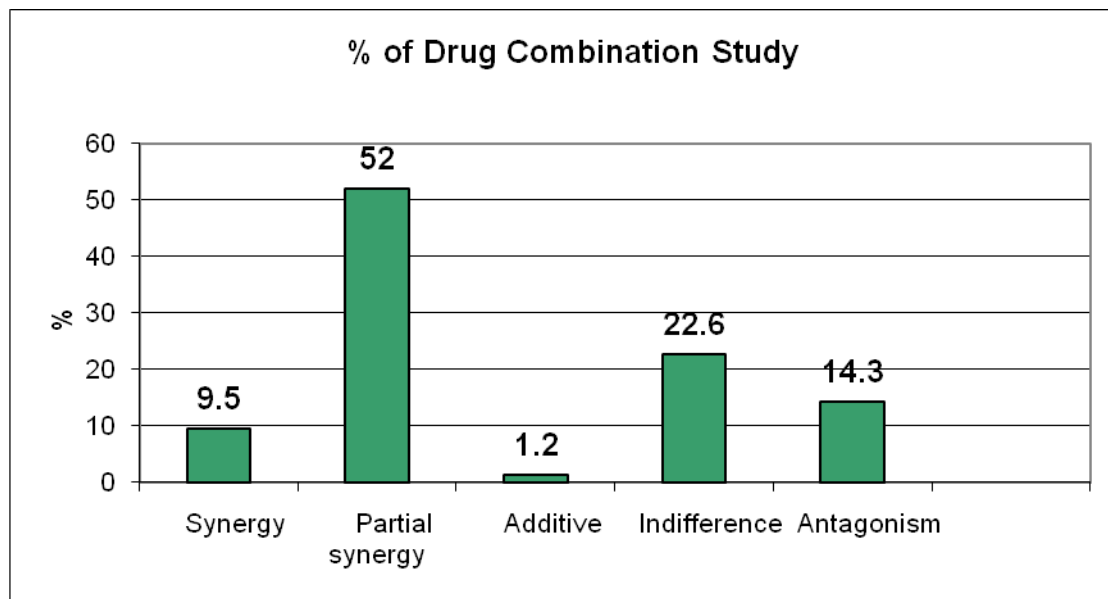

Figure16. Frequency percentage of *A. baumannii* isolates demonstrating antimicrobial susceptibilities in combinations of ciproxin and meropenem.

Outcome	Meropenem MIC ( $\mu\text{g/ml}$ )		
	$\leq 2$ ( n =26 )	$\geq 4$ and $\leq 8$ ( n =3 )	$\geq 16$ ( n =56 )
Synergy	0	1	7
Partial synergy	0	2	43
Additive	0	0	1
Indifference	14	0	0
Antagonism	12	0	0

Table8. *A. baumannii* synergy testing results as a function of meropenem MIC

Ciproxin MIC ( $\mu\text{g/ml}$ )			
Outcome	$\leq 2$ ( n =12 )	$\geq 4$ and $\leq 8$ ( n =42)	$\geq 16$ ( n=31 )
Synergy	0	2	5
Partial synergy	0	37	8
Additive	0	1	0
Indifference	1	2	16
Antagonism	11	0	2

Table9. *A. baumannii* synergy testing results as a function of ciproxin MIC

## PCR amplification for carbapenemases

PCR amplification and subsequent agarose gel electrophoresis of class D  $\beta$ -lactamase genes revealed that 100% of the isolates contained OXA-51 genes. The size of OXA-51 DNA gene fragment was found to be 353 bp. As shown in Table10, only two isolates contained OXA-58 gene fragment, its size was found to be 599 bp, and two isolates contained OXA-23 gene fragment of 501 bp. The majority of the isolates (63/85) carried the OXA-24 gene fragment of 246 bp (Figure 19). Only one isolate contained both OXA-58 and OXA-24 genes. These resistant genes were not detected in 19 isolates. Two of these isolates (2/19) were resistant to meropenem while the rest (17/19) were sensitive to this drug. The distribution of oxacillinases in *A. baumannii* susceptible and resistant to meropenem is shown in Figures 17 and 18.

MIC Meropenem	OXA-51	OXA-58	OXA-23	OXA-24
0.5	10	0	0	5
1.0	8	0	0	4
2.0	8	0	0	0
4.0	0	0	0	0
8.0	3	0	0	2
16	2	1	0	1
32	2	0	1	0
64	5	0	1	4
128	41	1	0	41
256	6	0	0	6

Table10. Number of isolates detected carrying carbapenemases genes

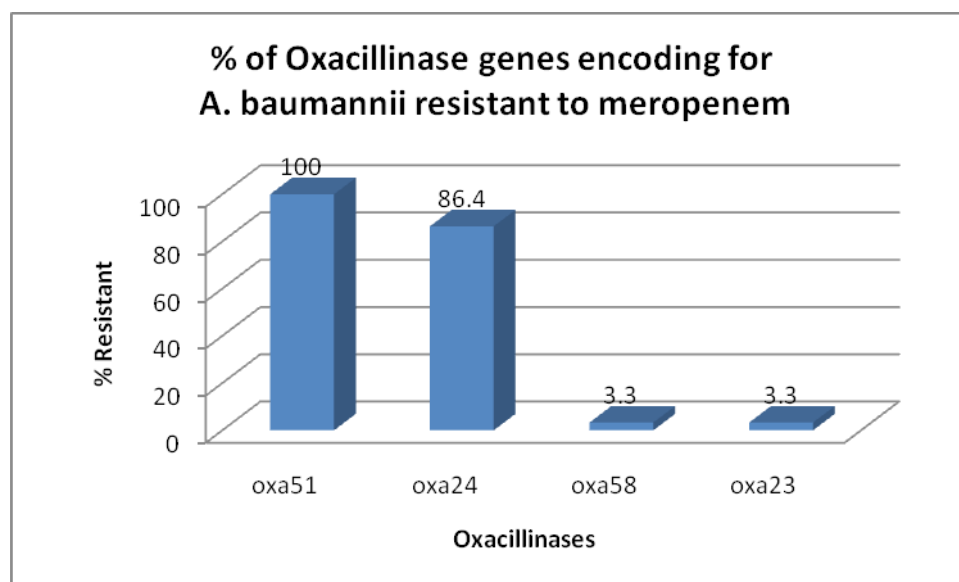

Figure 17. Class D beta lactamase (oxacillinase) expression in *A. baumannii* resistant to meropenem, 59 resistant and intermediate isolates.

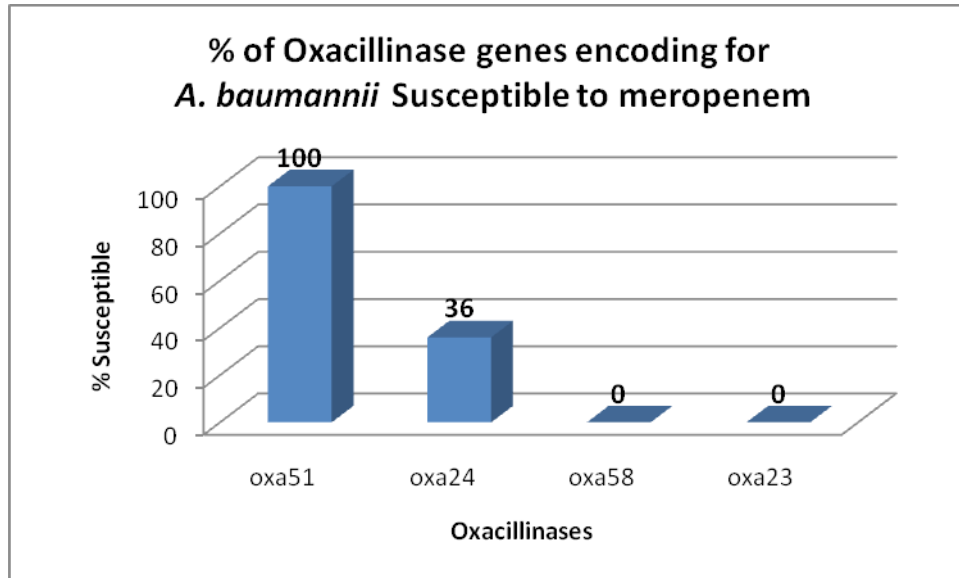

Figure18. Class D expression in *A. baumannii* susceptible to meropenem, 26 isolates.

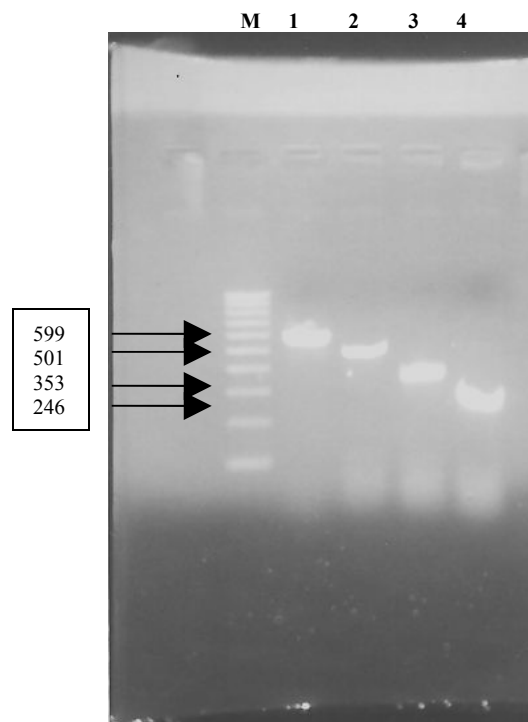



Figure19. Representative gel showing the PCR products for the different oxacillinase genes. Lane M: 100 bp ladder, Lane1: oxa58, lane 2: oxa23, lane 3: oxa-51, lane 4: oxa24.

M 1 2 3 4 5

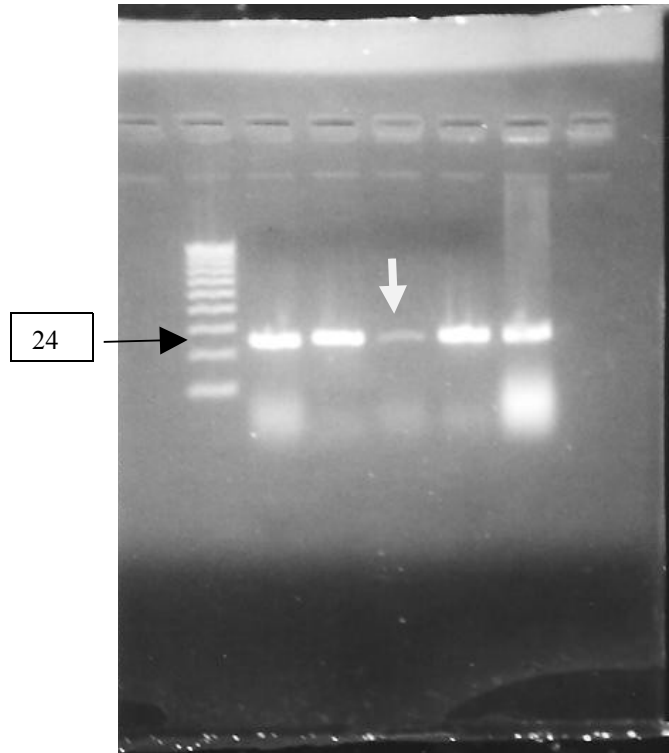

Figure 20. Representative gel showing the PCR products for Oxa-24. Lane M; 100-bp ladder, lanes 1,2, 4 and 5: resistant *A. baumannii* isolates to meropenem. Lane3: meropenem susceptible *A. baumannii* isolate (heteroresistant)

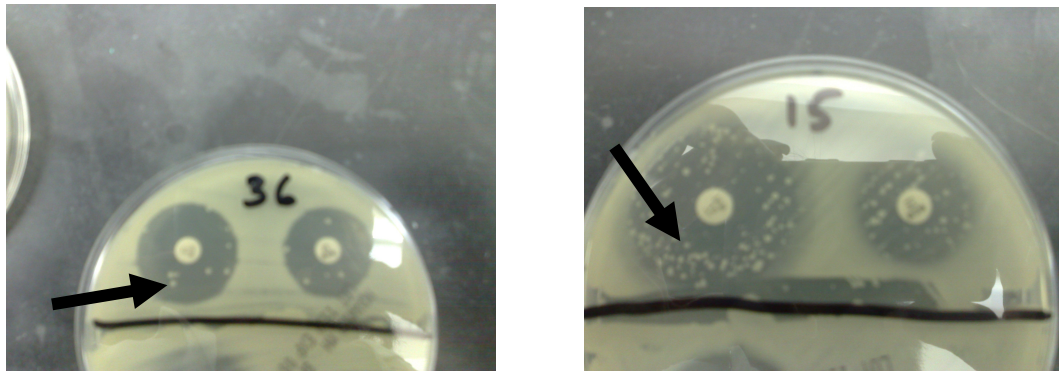

Figure 21. Detection of heteroresistant *A. baumannii* for meropenem. Heteroresistant colonies are located inside the susceptibility zones of imipenem and meropenem at the head of the arrow.

### PCR amplification of QRDR of *ParC* and *gyrA3*

The PCR product had the expected size of 343 bp for *gyrA* gene fragment and 197 bp for *ParC* gene fragment. After digestion with *HinfI* restriction enzyme those fragments which are carrying a mutation resulting in no digestion of fragment while those which are not carrying a mutation in QRDR generated two fragments of 144 and 53 bp for *ParC* ( Figure 23) fragment and 291 and 52 bp for *gyrA* (Figure 24). The correlation between the levels of MIC and mutations in the QRDR region is shown in Table 11 and Figure 22.

MIC μg /ml	N	<i>ParC</i> mutated	<i>ParC</i> Nonmutated	<i>GyrA</i> mutated	<i>GyrA</i> nonmutated
0.25≥MIC<2	12	0	12	0	12
2≥MIC<4	18	0	18	18	0
4≥MIC<32	34	0	34	34	0
32≥MIC≤128	21	21	0	21	0
<b>Sum</b>	85	21	64	73	12

Table11. Number of mutated isolates (uncut when digested with *HinfI*) and nonmutated ones (cut into 2 fragments when digested with *HinfI*)

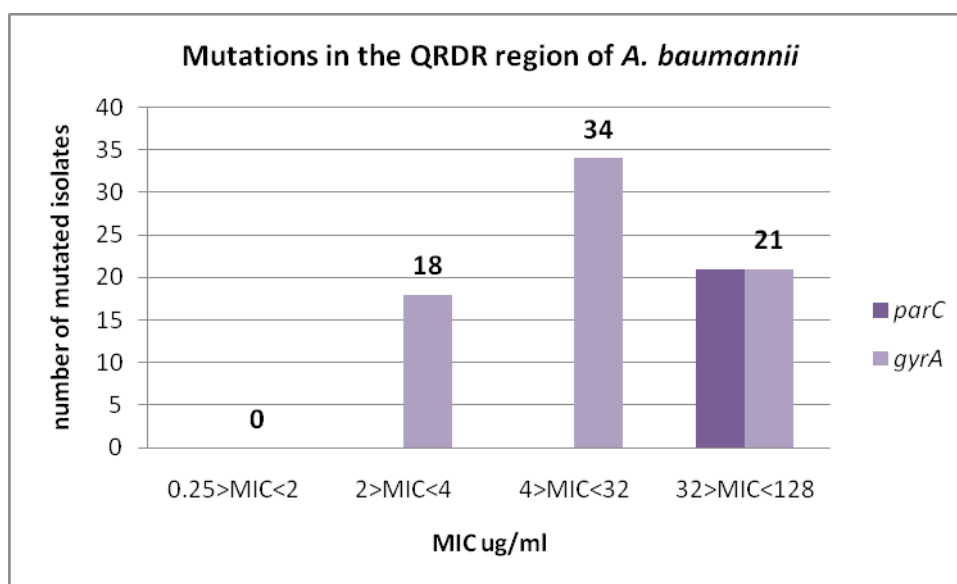

Figure 22. Correlation of mutations in the *gyrA* and *parC* according to individual MICs obtained for *A. baumannii* isolates.

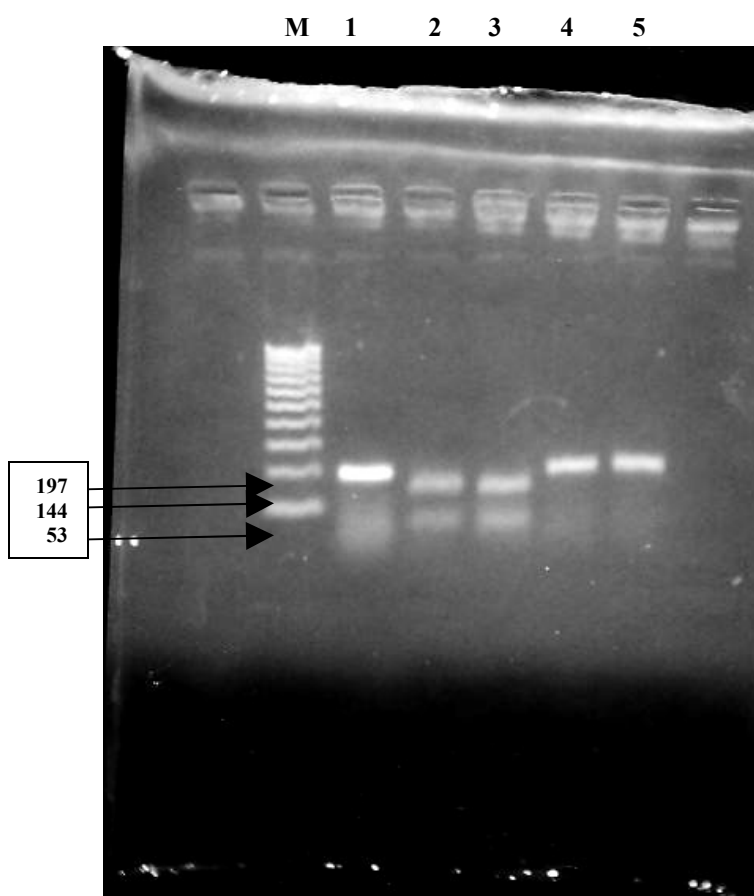

Figure 23. Representative gel for *parC* gene. Lane M: 100 bp ladder. Lane1: undigested PCR product. Lane2: *A. baumannii* susceptible to ciproxin and digested with *Hinf*I (Cut). Lane 3: *A. baumannii* resistant to ciproxin (MIC=16) and digested with *Hinf*I (Cut). Lane4: *A. baumannii* resistant to ciproxin (MIC=32) and digested with *Hinf*I (uncut). Lane5: *A. baumannii* resistant to ciproxin (MIC=128) and digested with *Hinf*I (uncut).

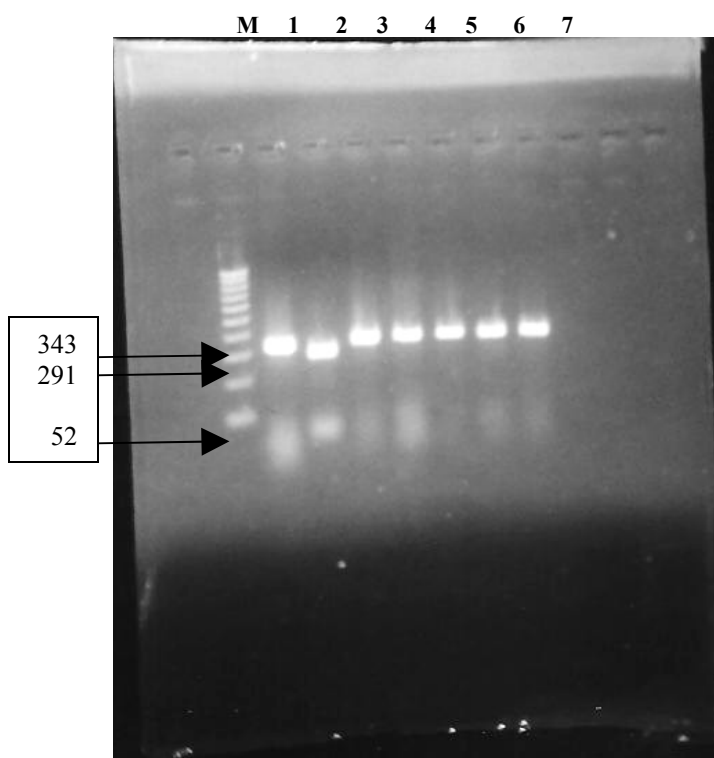

Figure 24: Representative gel for *gyrA* products of *A. baumannii*. Lane M: 100 bp ladder. Lane1: undigested PCR product. Lanes 2, 3, 4, 5, 6 and 7: digested PCR products by *HinfI* with MICs of 0.5, 4, 8, 32, 64 and 128 respectively. Lane 2: susceptible (Cut). Lane 3,4,5,6 and 7 resistant (uncut).

The sequencing of representative PCR products of *gyrA* gene revealed that there was a mutation in codon 83 in which the serine was substituted to leucine in those  $\geq 2$   $\mu\text{g/ml}$  ( Intermediate and resistant ) while those which were sensitive showed no mutation. No results were obtained for mutation in *parC* gene in analyzing the sequences.

## DISCUSSION

*A. baumannii* is an important causative agent of nosocomial infections. In many cases, carbapenems have proved to be the drug of choice in treating these infections; however, a number of reports worldwide highlighted the occurrence of multidrug-resistant *A. baumannii* including carbapenem. Combinations of agents that exhibit synergy or even partial synergy could be an option to improve the treatment of patients with infections caused by resistant *A. baumannii*. In this study, meropenem resistance was seen in 69.4% (59/85) of the isolates and 85.9% (73/85) were resistant to ciproxin. The checkerboard method used to check combinations of antibiotics revealed that meropenem and ciproxin were synergistic in 9.5% (8/85), partially synergistic in 52% (44/85), additive in 1.2% (1/85), indifferent in 22.6% (19/85), and antagonistic in 14.3 (12/85). Thus synergism and partial synergism could be apparent in the majority of isolates, particularly in those with elevated meropenem and ciproxin MICs ( $\geq 16 \mu\text{g/ml}$ ). Our results revealed the presence of synergy in cases where elevated MICs for both antibiotics ( $\geq 32 \mu\text{g/ml}$ ), while partial synergy was seen in cases where one of the two antibiotics was elevated  $\geq 32\mu\text{g/ml}$  and the other resistant with MICs  $\geq 4\mu\text{g/ml}$  and  $\leq 32\mu\text{g/ml}$ . Indifference was observed in susceptible or intermediate to one of the two antibiotics and resistant to the other with elevated MICs. Antagonism was seen in all isolates susceptible to both antibiotics with MICs  $\leq 2 \mu\text{g/ml}$ . Additive reaction was seen in only one isolate that was resistant to meropenem with MIC of  $128 \mu\text{g/ml}$  and  $4 \mu\text{g/ml}$  for ciproxin.

There is a wealth of literature investigating antimicrobial combinations for *A. baumannii*. In one study, combinations of imipenem and amikacin, ampicillin/sulbactam and amikacin revealed that 100% (14/14) and 92.9% (13/14) of isolates respectively were synergistic or partially synergistic. (53). Another study performed on

combination of meropenem and sulbactam for 48 isolates collected from Brazilian hospitals revealed that 77.1% (37/48) isolates were synergistic and partially synergistic (54). Five strains of MDR *A. baumannii* tested in a study conducted in London on combinations of polymyxin B with imipenem, azithromycin and rifampicin using Etest, (55) did not show marked synergy. The study supported that drug combination is an important aspect in optimization of therapy. Moreover, the drug combination meropenem and ciproxin revealed synergy and partial synergy of 61%, it can be used as guide to clinical efficacy where appropriate therapies should be further investigated.

Recently, *A. baumannii* is implicated in frequent nosocomial infections. Therefore it is important to investigate the relationship between genotyping and drug resistance of strains isolated during epidemics or outbreaks in hospitals. One of the important goals of this study was to correlate resistance phenotypes and the genetic determinants of resistance in *A. baumannii* for meropenem and ciproxin. Resistance to meropenem was seen in 69.4% of all isolates. Expression of class D beta-lactamases revealed that OXA-51 was present in all isolates, OXA-24 genes were expressed in 92.4% of the resistant isolates, OXA-23 genes were expressed in only two isolates, 3.4%, and two isolates expressed OXA-58 genes, 3.4%. Only one of the 59 isolates resistant to meropenem expressed both genes OXA-58 and OXA-24. Two meropenem-resistant isolates did not express any of the three oxacillinase genes investigated in this study, OXA-23, OXA-24 or OXA-58, indicating that the mechanism of resistance for these isolates were undefined subgroups of OXA enzymes, or alternative mechanisms of resistance. There were 30.6% of isolates susceptible to meropenem. All of these isolates expressed the OXA-51 genes, 36.4% of them expressed the OXA-24 genes as shown in Figure 20(the bands were not sharp).



The expression of the OXA-24 genes in these 9 meropenem-susceptible isolates can be explained by two concepts: a mutation on the OXA-24 gene (encoding the carbapenemase) caused the gene to be silent; evolution of heteroresistance: (subpopulations of genetically identical subclones that are more resistant than the original parent) may explain the second concept. In this study, the evolution of heteroresistance was investigated. Heavy suspension (2 McFarland) of each of the 9 isolates was spread onto Mueller Hinton plates and meropenem and imipenem discs were added, the plates were incubated overnight in a non-CO<sub>2</sub> incubator at 37° C. The detection of small number of colonies within the susceptible zone indicates heteroresistance as shown in Figure 21 . Some of these colonies were taken and streaked on BAP to confirm that the correct identity of the colonies as *A. baumannii* and the PCR was repeated to confirm the presence of OXA-24 gene. The results obtained from this experiment proved that isolates tested were true heteroresistant strains.

These results warrant that *A. baumannii* susceptible to meropenem with routine procedures must be confirmed by additional screening methods to detect heteroresistance. This is extremely important for clinicians and physicians to prevent selection pressure for resistance.

A study in USA, on isolates recovered from Military and civilian patients treated at the Walter Reed Army Medical Center, OXA-23 and OXA-58 like carbapenemase genes were found in 90% of the meropenem resistant isolates, whereas OXA-69 (from the same cluster of OXA-51) was detected in 97% of isolates which were susceptible and resistant to meropenem (56).

In another study done in southern Europe, the Balkan, and central Turkey, 22 out of 42 isolated were positive to OXA-58 gene and 2 isolates for OXA-23 and 10 isolates

had OXA-40 (from the same cluster of OXA-24) (32), while OXA-40 was disseminated in Portugal (33).

A study was done on 30 carbapenem nonsusceptible *Acinetobacter spp* isolates collected in Argentina, Kuwait and Britain had revealed the occurrence of OXA-51 gene in 28/30 isolates and 30/30 had OXA-58 (34).

The OXA alleles encoding known carbapenemases were studied in 250 isolates of *Acinetobacter spp.* from the UK and the results obtained were 232/250 had OXA-51 gene, 154/250 isolates had OXA-23 gene, 20/250 isolates had OXA-58 gene while OXA-24 was not detected in any isolate (57).

Comparing our study with the previous studies, OXA-51 genes were detected in all isolates irrespective of the levels of carbapenem susceptibility, consistent with the view that they are intrinsic to *A. baumannii*. Therefore, the presence of this intrinsic gene does not correlate with the level of carbapenem resistance of the isolate.

Although OXA-24 was not detected in the UK isolates, it was prevalent in the isolates tested in this study. The occurrence of OXA-58 gene was verified in strains tested in the three continents, our study indicated that this gene occurs in Palestine as well.

According to the antimicrobial susceptibility tests conducted in this project, 86% of isolates were resistant to ciproxin. All isolates carry the *gyrA* and *parC* genes in the QRDR. Resistance to quinolones can be due to mutations in these genes. In this study, PCR products for *gyrA* (343 bp) and *parC* (197 bp) were digested with *HinfI* restriction enzyme. The restriction site for *HinfI* on the *gyrA* gene is located at codon 83 and at codon 80 on the *parC* gene. Mutations at codon 83 and 80 in these respective genes (*gyrA* and *parC*) will result in non-digestion at these sites giving the full length PCR product. On the other hand, non-mutated genes will be restricted by

the *HinfI* enzyme giving two fragments of 291 and 52 bps for *gyrA* and 144 and 53 bps for *parC* genes.

Our results indicated the presence of correlation between resistance to ciproxin and mutations at *gyrA*. It was found in this study that isolates with MIC  $\geq 2$   $\mu\text{g/ml}$  was not digested with the restriction enzyme, proving to be mutated at codon 83. Isolates with MICs  $\leq 1$   $\mu\text{g/ml}$  were digested into two fragments indication no mutations in the *gyrA* gene. The results obtained by restriction with *HinfI* were verified by sequencing. The results obtained by sequencing revealed the presence of substitution of serine to leucine at codon 83.

For *parC*, MICs for ciproxin of  $\leq 32$   $\mu\text{g/ml}$  in all isolates, our results revealed the absence of mutations. Therefore, the presence of mutations in the *parC* gene must coincide with mutations in the *gyrA* gene. The essence of our results suggests that *parC* gene from *A. baumannii* is a secondary target for quinolones and that mutation at codon 80 of *parC* when combined with mutation at codon 83 of *gyrA*, may render *A. baumannii* highly resistant to quinolones. It is apparent that our results are in agreement with other studies done worldwide. In one study, 147 isolates of *A. baumannii* were collected from various hospitals in Europe and USA, all quinolone resistant isolates showed mutations at codon 83 of *gyrA* gene while those MIC  $\geq 32$   $\mu\text{g/ml}$  showed mutations at codon 80 and 84 of *parC* gene.(45). A similar study was done on isolates from three Spanish hospitals, revealed the same forementioned results.(58). A previous study conducted in Spain in 1995, similar results were obtained in addition to mutations in the *gyrA* gene at codons 81 and 84 (44). In this study as well as other studies, only small regions of the *gyrA* and *parC* genes were examined. It is possible that mutations at other locations or in other genes may contribute to ciproxin resistance in *A. baumannii*.

Sequencing of the *parC* gene products did not reveal the presence of mutations. It was apparent in our results obtained by the RFLP test that these mutations existed. This controversy can be explained by examining the flanking regions of the *parC* gene products. The mutations may be found in these regions or juxtaposition to it. The sequences obtained in the flanking regions were not clear enough to draw a definite conclusion in this aspect. Therefore, in order to determine the presence of mutations in the flanking regions of the *parC* gene products, new experiments must be designed using primers that will amplify this region.

## **Recommendations**

- To establish a functional National and Hospital Infection Control Committee

- The combination of antibiotics conducted in-vitro must be confirmed by in-vivo studies.
- Combinations should be performed by using broth dilution or agar dilution methods.
- Synergy and partial synergy results can be used as a guide to the efficacy of both antibiotics tested where further therapies should be investigated.
- Strict rules must be implemented in hospitals to curb the spread of MDR *A. baumannii*.
- Further studies should be conducted by PFGE to determine the relatedness of the strains and their correlation with the resistance genotypes
- Any *A. baumannii* isolate susceptible to carbapenems must be retested using heavy inoculum (2 McFarland) to rule out the presence of heteroresistance to prevent selection pressure.

## References

- 1- Brisou, J., and Prevot, A. R. Studies on bacterial taxonomy. X. The revision of species under Achromobacter group. Ann. Inst. Pasteur (Paris). 1954;86:722–728

- 2- Baumann, P., M. Doudoroff, and R. Y. Stanier. A study of the *Moraxella* group. II. Oxidative-negative species (genus *Acinetobacter*). J. Bacteriol. 1968; 95:1520–1541.
- 3- Rossau, R., A. van Landschoot., M. Gillis, and J. de Ley. Taxonomy of *Moraxellaceae* fam. nov., a new bacterial family to accommodate the genera *Moraxella*, *Acinetobacter*, and *Psychrobacter* and related organisms. Int. J. Syst. Bacteriol. 1991; 41:310-319.
- 4- Elmer W. Koneman, Stephen D. Allen, William M. Janda, Paul C. Schreckenberger, and Washington C. Winn. Color atlas and textbook of diagnostic microbiology. Fourth edition. p. 213-214, 611-616, 628-629, 651-653.
- 5- Allen D, Harman B. Mandell GL, Bennett JE, Dolin R, editors. Mandell, Douglas, and Bennett's. Principles and practice of Infectious Diseases. 2000; 2339-2344.
- 6-Aharon Abbo, Shiri Navon Venezia. Orly Hammer-Mutz, Tami Krichali, Yardena Siegman-Igra, and Yahuda Carmeli. Multidrug-Resistant *Acinetobacter baumannii*. Emerging Infectious Diseases. Medscape Today. 2005; 11(1):22-29.
- 7-Vila, J., Marti, S., Sanchez-Cespedes, J. "Porins, efflux pumps and multidrug resistance in *Acinetobacter baumannii*. Journal of Antimicrobial Chemotherapy. 2007 ;59(6):1210-5.
- 8- Gaynes, R., and J. R. Edwards. Overview of nosocomial infections caused by gram-negative bacilli. Clin. Infect. Dis. 2005; 41:848–854.
- 9- Anstey, N. M., B. J. Currie, M. Hassell, D. Palmer, B. Dwyer, and H. Seifert. Community-acquired bacteremic *Acinetobacter* pneumonia in tropical Australia is caused by diverse strains of *Acinetobacter baumannii*, with carriage in the throat in at-risk groups. J. Clin. Microbiol. 2002. 40: 685–686.
- 10- Anstey, N. M., B. J. Currie, and K. M. Withnall. 1992. Community-acquired *Acinetobacter* pneumonia in the Northern Territory of Australia. Clin. Infect. Dis. 14:83–91.
- 11- Bick, J. A., and J. D. Semel. Fulminant community-acquired *Acinetobacter* pneumonia in a healthy woman. Clin. Infect. Dis. 1993. 17:820–821.
- 12- Gottlieb, T., and D. J. Barnes. Community-acquired *Acinetobacter* pneumonia. Aust. N. Z. J. Med. 1989; 19:259–260.
- 13- Leung, W. S., C. M. Chu, K. Y. Tsang, F. H. Lo, K. F. Lo, and P. L. Ho. Fulminant community-acquired *Acinetobacter baumannii* pneumonia as a distinct clinical syndrome. Chest. 2006; 129:102–109.

- 14- Wisplinghoff, H., T. Bischoff, S. M. Tallent, H. Seifert, R. P. Wenzel, and M. B. Edmond. Nosocomial bloodstream infections in US hospitals: analysis of 24,179 cases from a prospective nationwide surveillance study. *Clin. Infect. Dis.* 2004; 39:309–317.
- 15- Trottier, V., P. G. Segura, N. Namias, D. King, L. R. Pizano, and C. I. Schulman. 2007. Outcomes of *Acinetobacter baumannii* infection in critically ill burned patients. *J. Burn Care Res.* 28:248–254.
- 16- Murray, C. K., S. A. Roop, D. R. Hospenthal, D. P. Dooley, K. Wenner, J. Hammock, N. Taufen, and E. Gourdine. Bacteriology of war wounds at the time of injury. *Mil. Med.* 2006; 171:826–829.
- 17- Johnson, E. N., T. C. Burns, R. A. Hayda, D. R. Hospenthal, and C. K. Murray. Infectious complications of open type III tibial fractures among combat casualties. *Clin. Infect. Dis.* 2007; 45:409–415.
- 18- Metan, G., E. Alp, B. Aygen, and B. Sumerkan. *Acinetobacter baumannii* meningitis in post-neurosurgical patients: clinical outcome and impact of carbapenem resistance. *J. Antimicrob. Chemother.* 2007; 60:197–199.
- 19- Simor AE, Lee M, Vearncombe M, Jones-Paul L, Barry C, Gomez M et al. An outbreak due to multiresistant *Acinetobacter baumannii* in a burn unit: risk factors for acquisition and management. *Infect Control Hosp Epidemiol* 2002; 23(5):261-267.
- 20- Lorian, Victor. *Antibiotics in Laboratory Medicine*, 5<sup>th</sup> Edition. Copyright Lippincott Williams & Wilkins 2005
- 21- Wayne, PA. National Committee for Clinical Laboratory Standards. *Methods for dilution antimicrobial susceptibility tests for bacteria that grow aerobically.*: National Committee for Clinical Laboratory Standards, 2003. NCCLS document M7-A6.
- 22- Chang, S. C., Y. C. Chen, K. T. Luh, and W. C. Hsieh. In vitro activities of antimicrobial agents, alone and in combination, against *Acinetobacter baumannii* isolated from blood. *Diagn. Microbiol. Infect. Dis.* 1995; 23:105–110.
- 23- Drago, L., E. De Vecchi, L. Nicola, A. Colombo, A. Guerra, and M. R. Gismondo. Activity of levofloxacin and ciprofloxacin in combination with cefepime, ceftazidime, imipenem, piperacillin-tazobactam and amikacin against different *Pseudomonas aeruginosa* phenotypes and *Acinetobacter spp.* *Chemotherapy.* 2004; 50:202–210.
- 24- Roussel-Delvallez, M., F. Wallet, F. Delpierre, and R. J. Courcol. In vitro bactericidal effect of a beta-lactam\_aminoglycoside combination against multiresistant *Pseudomonas aeruginosa* and *Acinetobacter baumannii*. *J. Chemother.* 1996; 8:365–368.
- 25- Joly-Guillou, M. L., M. Wolff, R. Farinotti, A. Bryskier, and C. Carbon. In vivo activity of levofloxacin alone or in combination with imipenem or amikacin in a mouse model of *Acinetobacter baumannii* pneumonia. *CLIN. MICROBIOL. REV.* 2000; 46:827–830.

- 26- Sader, H. S., P. R. Rhomberg, and R. N. Jones. In vitro activity of beta-lactam antimicrobial agents in combination with aztreonam tested against metallo-beta-lactamase-producing *Pseudomonas aeruginosa* and *Acinetobacter baumannii*. J. Chemother. . 2005; 17:622–627.
- 27- Montero, A., J. Ariza, X. Corbella, A. Domenech, C. Cabellos, J. Ayats, F. Tubau, C. Borraz, and F. Gudiol. Antibiotic combinations for serious infections caused by carbapenem-resistant *Acinetobacter baumannii* in mouse pneumonia model. J. Antimicrob. Chemother. 2004; 54:1085–1091.
- 28- Fluit, AD C., Maarten R. Visser, and Franz-Josef Schmitz Eijkman. Molecular Detection of Antimicrobial Resistance. Clinical Microbiology Reviews CMR. 2001; 14(4):836–871.
- 29- Pore, L., and P. Nordmann. Carbapenem resistance in *Acinetobacter baumannii*: mechanisms and epidemiology. Clin. Microbiol. Infect. 2006; 12:826–836.
- 30- Queenan, A. M., and K. Bush. Carbapenemases: the versatile betalactamases. Clin. Microbiol. Rev. 2007; 20:440–458.
- 31- Walsh, T. R., M. A. Toleman, L. Pore, and P. Nordmann. Metallobeta-lactamases: the quiet before the storm? Clin. Microbiol. Rev. 2005; 18:306–325.
- 32- Maque S, Pore L, Heritier C, Brisse S, Dolres Blasco M, Filip R, Coman G, T, and Nordmann P. Naas Regional occurrence of Plasmid-Mediated Carbapenem-Hydrolyzing Oxaacillinase OXA-58 in *Acinetobacter spp.* In Europe. Journal of Clinical Microbiology. 2005; 43(9): 4885-4888.
- 33- Da Silva G.J., Quinteira S., Bertolo E., Sousa J.C., Gallego L., Daurte A., L. Long term and Peixe dissemination of an OXA-40 carbapenemase-producing *Acinetobacter baumannii* clone in the Iberian Peninsula. Journal of Antimicrobial Chemotherapy. 2004; 54: 255-258.
- 34- Coelho J, Woodford N., Afzal-Shah M., and Livermore D. Occurrence of OXA-58-like carbapenemases in *Acinetobacter spp.* Collected over 10 years in three Continents. Antimicrobial Agents and Chemotherapy. 2006; 50 (2) :756-758.
- 35- Brown, S., and S. Amyes. OXA (beta)-lactamases in *Acinetobacter*: the story so far. J. Antimicrob. Chemother. 2006; 57:1–3.
- 36- Jeon, B. C., S. H. Jeong, I. K. Bae, S. B. Kwon, K. Lee, D. Young, J. H. Lee, J. S. Song, and S. H. Lee. Investigation of a nosocomial outbreak of imipenem-resistant *Acinetobacter baumannii* producing the OXA-23 -lactamase in Korea. J. Clin. Microbiol. 2005; 43:2241–2245.
- 37- Da Silva, G. J., S. Quinteira, E. Bertolo, J. C. Sousa, L. Gallego, A. Duarte, and L. Peixe. Long-term dissemination of an OXA-40 carbapenemase-producing



*Acinetobacter baumannii* clone in the Iberian Peninsula. J. Antimicrob. Chemother. 2004; 54:255-258.

38- Lopez-Otsoa, F., L. Gallego, K. J. Towner, L. Tysall, N. Woodford, and D. M. Livermore. Endemic carbapenem resistance associated with OXA-40 carbapenemase among *Acinetobacter baumannii* isolates from a hospital in northern Spain. J. Clin. Microbiol. 2002; 40:4741-4743

39- Poirel, L., S. Marque, C. Heritier, C. Segonds, G. Chabanon, and P. Nordmann. OXA-58, a novel class D  $\beta$ -lactamase involved in resistance to carbapenems in *Acinetobacter baumannii*. Antimicrob. Agents Chemother. 2005; 49:202-208.

40- Heritier, C., A. Dubouix, L. Poirel, N. Marty, and P. Nordmann. A nosocomial outbreak of *Acinetobacter baumannii* isolates expressing the carbapenem-hydrolyzing oxacillinase OXA-58. J. Antimicrob. Chemother. 2005; 55:115- 118.

41- Marque, S., L. Pore, C. Heritier, S. Brisse, M. D. Blasco, R. Filip, G. Coman, T. Naas, and P. Nordmann. Regional occurrence of plasmidmediated carbapenem-hydrolyzing oxacillinase OXA-58 in *Acinetobacter spp.* in Europe. J. Clin. Microbiol. 2005; 43:4885–4888

42-Coelho, J., N. Woodford, M. Afzal-Shah, and D. Livermore. Occurrence of OXA-58-like carbapenemases in *Acinetobacter spp.* collected over 10 years in three continents. Antimicrob. Agents Chemother. 2006; 50:756–758.

43- Vila J, Ribera A, Marco F, Ruiz J, Mensa J, Chaves J, Henandez G, and De Anta M. Activity of ciprofloxacin, compared with six other quinolones, against *Acinetobacter baumannii* clinical isolates. Journal of Antimicrobial Chemotherapy. 2002; 49(3) : 471-477

44-Jordi Vila, Joaquim Ruiz, PilarI Gon~ I, Angeles Marcos, and Teresa JimenezI de Anta. Mutation in the gyrA Gene of Quinolone-Resistant Clinical Isolates of *Acinetobacter baumannii*. Antimicrobial Agents and Chemotherapy. 1995; 39(5): 1201–1203.

45-Hilmar Wisplinghoff, Mathias Decker, Christiane Haefs, Oleg Krut, Georg Plum and Harald Seifert. Mutations in gyrA and parC associated with resistance to fluoroquinolones in epidemiologically defined clinical strains of *Acinetobacter baumannii*. Journal of Antimicrobial Chemotherapy. 2003; 51, 177–180

46-Ahmed Hamouda and Sebastian G. B. Amyes. Novel gyrA and parC point mutations in two strains of *Acinetobacter baumannii* resistant to ciprofloxacin. Journal of Antimicrobial Chemotherapy. 2004;

47- Federico Perez,<sup>1</sup> Andrea M. Hujer,<sup>2</sup> Kristine M. Hujer,<sup>2</sup> Brooke K. Decker,<sup>3</sup> Philip N. Rather,<sup>4</sup> and Robert A. Bonomo<sup>2,3</sup>. Global Challenge of Multidrug-Resistant *Acinetobacter baumannii*. Antimicrobial Agent and Chemotherapy. 2007; 51(10): 3471–3484

- 48Su, X. Z., J. Chen, T. Mizushima, T. Kuroda, and T. Tsuchiya. AbeM, an H<sub>2</sub>-coupled *Acinetobacter baumannii* multidrug efflux pump belonging to the MATE family of transporters. *Antimicrob. Agents Chemother.* 2005; 49: 4362–4364.
- 49-Turton, J. F., M. E. Kaufmann, M. J. Gill, R. Pike, P. T. Scott, J. Fishbain, D. Craft, G. Deye, S. Riddell, L. E. Lindler, and T. L. Pitt. Comparison of *Acinetobacter baumannii* isolates from the United Kingdom and the United States that were associated with repatriated casualties of the Iraq conflict. *J. Clin. Microbiol.* 2006; 44:2630–2634.
- 50-Hujer, K. M., N. S. Hamza, A. M. Hujer, F. Perez, M. S. Helfand, C. R. Bethel, J. M. Thomson, V. E. Anderson, M. Barlow, L. B. Rice, F. C. Tenover, and R. A. Bonomo. Identification of a new allelic variant of the *Acinetobacter baumannii* cephalosporinase, ADC-7 beta-lactamase: defining a unique family of class C enzymes. *Antimicrob. Agents Chemother.* 2005, 49:2941–2948.
- 51-Anton Y. Peleg,<sup>1</sup> Harald Seifert,<sup>2</sup> and David L. Paterson. *Acinetobacter baumannii*: Emergence of a Successful Pathogen. *Clinical Microbiology Review.* 2008; 21 (3) : 538–582.
- 52-Antonia Zapantis, Mary Lopez, Emily Hoffman, Angelica Lopez, and Grace Hamilton. The Use of Colistin in Multidrug-Resistant Infections. *Hospital Pharmacy.* 2007; 42(12): 1127–1138
- 53-MB Marques, ES Brookings, SA Moser, PB Sonke and KB Waites. Comparative in vitro antimicrobial susceptibilities of nosocomial isolates of *Acinetobacter baumannii* and synergistic activities of nine antimicrobial combinations. *Antimicrobial Agents and Chemotherapy.* 1997; 41(5): 881-885,
- 54- Carlos R.V. Kiffer, Jorge L.M Sampaio, Surniko Sinto, Carmen P. Oplustil, Paula C.M. Koga, Andrea C. Arruda . Philip J. Turner, and Caio Mendes. In vitro synergy test of meropenem and sulbactam against clinical isolates of *Acinetobacter baumannii*. *Diagnostic microbiology and infectious disease.* 2005; 52: 317-322.
- 55-David W Wareham and David C Bean · In-vitro activity of polymyxin B in combination with imipenem, rifampicin and azithromycin versus multidrug resistant strains of *Acinetobacter baumannii* producing OXA-23 carbapenemases. *Ann Clin Microbiol Antimicrob.* 2006; 5: 10.
- 56-23-Hujer KM, Hujer AM, Hulten EA, Bajaksouzian S, Adams JM, Donskey CJ, Ecker DJ, Massire C, Eshoo MW, Sampath R, Thomson JM, Rather PN, Craft DW, Fishbain JT, Ewell AJ, Jacobs MR, Paterson DL, Bonomo RA. Analysis of antibiotic resistance genes in multidrug-resistant *Acinetobacter* sp. isolates from military and civilian patients treated at the Walter Reed Army in medical center. *Antimicrobial Agents Chemotherapy.* 2006 ;50(12):4114.
- 57-Woodford, Neil (N); Ellington, Matthew J (MJ); Coelho, Juliana M (JM); Turton, Jane F (JF); Ward, M Elaina (ME); Brown, Susan (S); Amyes, Sebastian G B (SG); Livermore, David M (DM); Multiplex PCR for genes encoding prevalent OXA

carbapenemases in *Acinetobacter spp.* International Journal of Antimicrobial agents.2006; 27(4): 351-353

58- Jordi Vila, Joaquim Ruiz, Pilar Goñi and Teresa Jimenez de Anta. Quinolone-resistance mutations in the topoisomerase IV parC gene of *Acinetobacter baumannii*. Journal of Antimicrobial Chemotherapy. (1997); 39: 757–762